

PRIMER VSAR 2.3.0

Setup Guide

April 2026



Chyron PRIME VSAR Setup Guide • 2.3.0 • April 2026 • This document is distributed by Chyron in online (electronic) form only, and is not available for purchase in printed form.

This document is protected under copyright law. An authorized licensee of Chyron PRIME VSAR may reproduce this publication for the licensee's own use in learning how to use the software. This document may not be reproduced or distributed, in whole or in part, for commercial purposes, such as selling copies of this document or providing support or educational services to others.

Product specifications are subject to change without notice and this document does not represent a commitment or guarantee on the part of Chyron and associated parties. This product is subject to the terms and conditions of Chyron's software license agreement. The product may only be used in accordance with the license agreement.

Any third-party software mentioned, described or referenced in this guide is the property of its respective owner. Instructions and descriptions of third-party software are for informational purposes only, as related to Chyron products and does not imply ownership, authority or guarantee of any kind by Chyron and associated parties.

This document is supplied as a Setup Guide for Chyron PRIME VSAR. Reasonable care has been taken in preparing the information it contains. However, this document may contain omissions, technical inaccuracies, or typographical errors. Chyron and associated companies do not accept responsibility of any kind for customers' losses due to the use of this document. Product specifications are subject to change without notice.

Copyright © 2026 Chyron, ChyronHego Corp. and its licensors. All rights reserved.

Table of Contents

PRIME VSAR INSTALLATION.....	5
Installation Note.....	5
License.....	6
Cesium.....	8
PRIME VSAR Tools.....	9
PRIME VSAR Web.....	9
PRIME VSAR.....	12
Chyron Panels (Live Assist Panels).....	16
VIDEO SETUP.....	17
HAL Video Setup.....	17
PRIME VSAR: nDisplay integration.....	26
nDisplay Setup.....	26
PRIME VSAR OVERVIEW.....	57
Creating a PRIME VSAR Project.....	58
PRIME VSAR Configuration Panel.....	59
TESTING.....	90
Test Prime VSAR / Cesium connection.....	90
Cesium: Jitter and Glitches while you move the real camera.....	90
Test DataEngine/PRIME VSAR connection.....	91
Test Video Input.....	92
Procedure to report issues.....	96
PRIME VSAR: CAMIO INTEGRATION.....	97
Integration Overview.....	97
Camio Components.....	99
Camio Configuration.....	101
PRIME VSAR - CAMIO Integration Troubleshooting.....	110

- PRIME VSAR 2.3.0 or higher
- PRIME VSAR Tools 2.3.0
- Live Assist Panels 2.9.0 or higher
- CESIUM 5.6.0 or higher
- Data Engine 0.77.7 or higher
- Sentinel Driver 7.6.0
- License Updater 2.5.0 or higher
- CAMIO 4.11.2 or higher
- iSQ 3.7.1 or higher
- Endpoint 1.2.2 or higher

PRIME VSAR INSTALLATION

Installation and configuration steps.

 Supported platforms are Windows 10 x64 and Windows 11 x64.

Installation Note

Possible Windows Defender prompt, when trying to run installers. In some configuration, one may get a warning like the following:

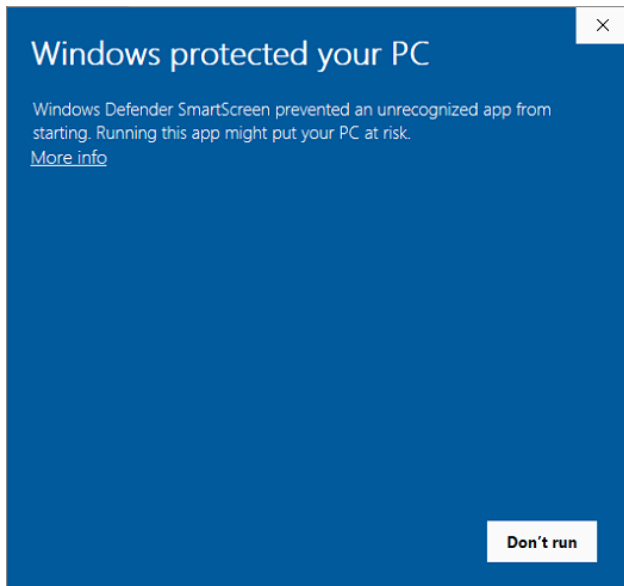

In that case, click on the “More info” link and then “Run anyway”

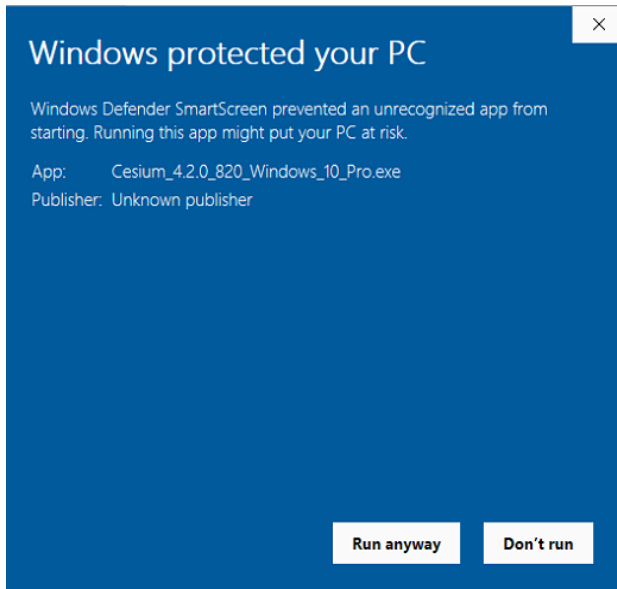

License

The following should be done only once, during the first installation.

For any license update, step 3) to 8) may be re-run, after features are added through Download Area (DA).

- 1) Plug the provided dongle in a USB port.
- 2) Install Sentinel System Driver.
- 3) Run ChyronHegoLicenseUpdater.
- 4) The updater will now show the current licenses.
- 5) Click Yes.
- 6) Make sure your license has been updated from within the DA.
 - a) VSAR(Fresh)
 - i) Option: Primitive Library
 - b) Cesium
 - i) Option: Parallax
- 7) The updater will now show the licenses to be updated.

- 8) Click Yes to update your license.
- 9) After this License updater will show you what licenses, options and what validity you have.
- 10) Please make sure this matches with your ordered configuration - namely Hal Inputs and outputs.

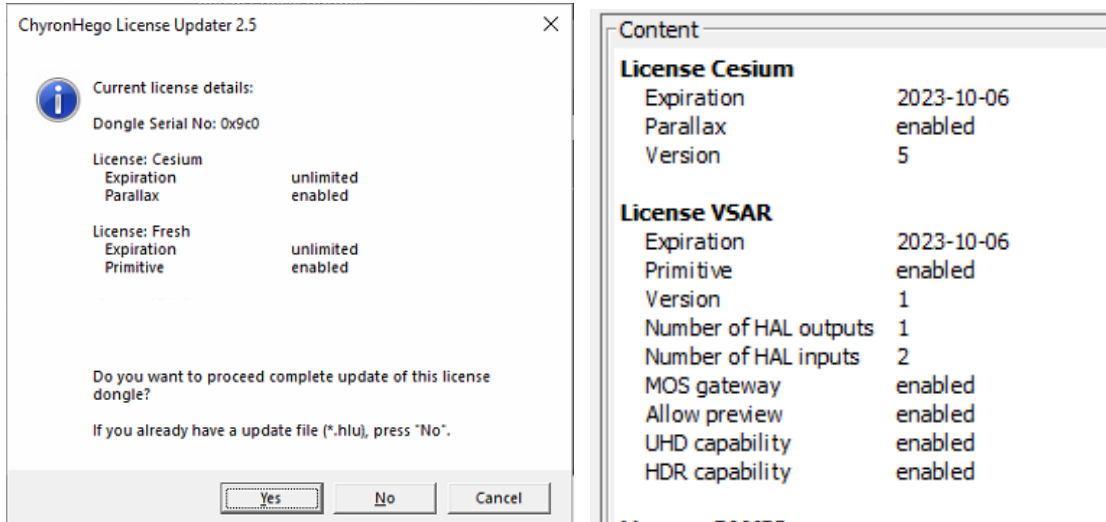

Cesium

Cesium is the software that manages translation of any (raw or pre-processed) tracking data coming from any provider into virtual 3D space coordinates.

- 1) Install Cesium running its corresponding Windows installer (should look like Cesium_5.6.NNN_Windows_10_Pro.exe - NNN being release ID).
- 2) Follow the instructions **above**, if Windows Defender prompts for an unrecognized application.
- 3) After the installation is done, you may want to try and run Cesium.
The following pop-up signals the software is not able to find the license.

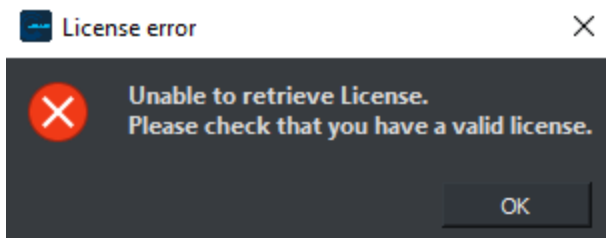

If not already done, plug in the USB dongle with the provided license and run again.
Cesium should open fine.

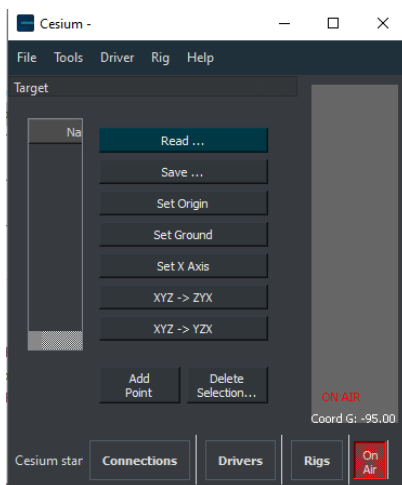

- 4) Open any of your tracking file or one provided as sample that can be found at %ProgramFiles%\Chyron\Cesium\data\cesium\samples
For instance Simulation.cs.
- 5) For setting up customized and/or your actual tracking environment, refer to the dedicated Cesium manual.

- 6) To check proper connection in PRIME VSAR, see below, in **Configuration Panel**.

PRIME VSAR Tools

PRIME VSAR Tools provide a couple of utilities that help PRIME VSAR users to manage the environment, like connection with the CAMIO Universe and other remote access software.

- 1) Install PRIME VSAR Tools, using related Windows installer.
- 2) Follow instructions **above**, if Windows Defender prompts for an unrecognized application.

PRIME VSAR Web

Gives the ability to remotely control aspects of PRIME VSAR from a web browser. It's part of the PRIME VSAR Tools installation.

Make sure the version of PRIME VSAR Tools matches the PRIME VSAR version or install PRIME VSAR Tools that is included in the PRIME VSAR installation to ensure full compatibility.

Services used by VSAR Web can be registered at the end of PRIME VSAR Tools installation:

PRIME VSAR



Completing the PRIME VSAR Tools Setup Wizard

Setup has finished installing PRIME VSAR Tools on your computer. The application may be launched by selecting the installed shortcuts.

Click Finish to exit Setup.

- Register EndPoint Handler service
- Register Request Dispatcher service
- Register Platinum Reconfigure service
- Register Vsar Controller service
- Start Vsar Controller service. Note: in order for Vsar Controller to start it needs to be registered above!
- Register Envoy service
- Start Envoy service. Note: in order for Envoy to start it needs to be registered above!
- Register VSAR Web service
- Start VSAR Web service. Note: in order for VSAR Web service to start it needs to be registered above!

Finish

We highly recommend enabling and starting all the marked services after installation.

Along with the VSAR Web service there is also Envoy service and VSAR Controller service that needs to be registered and running in order for VSAR Web to function properly.

Services can be seen if they are registered and are running in the Services window (Win + R - "services.msc"):

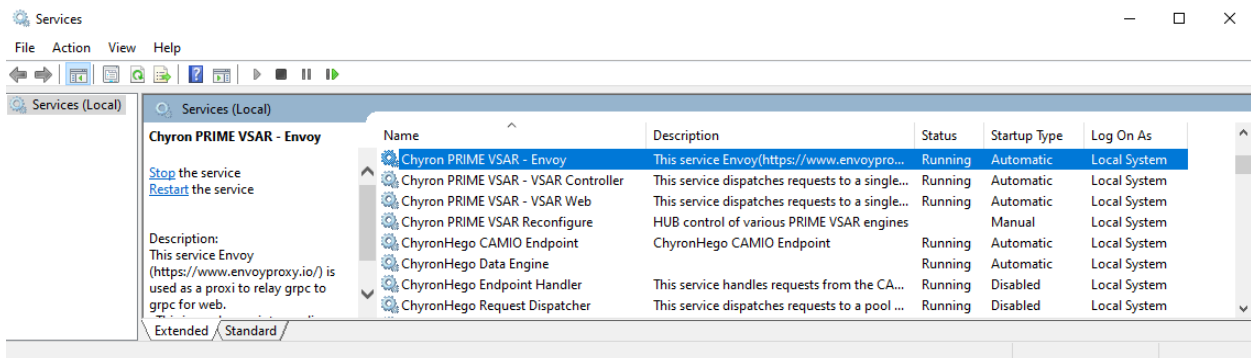

VSAR Web configuration

By default VSAR Web is hosted on the Local machine and can be accessed on <http://localhost:8080/> or on local network with the ip address of the machine followed by the port (:8080). This port can be changed in the website configuration file VsarWebProd.env that is located in the PRIME VSAR Tools installation folder bin\config\VsarWebProd.env.

There is a separate configuration file VSAR Web, the static website located in PRIME VSAR Tools installation folder%ProgramFiles%/Chyron/PRIME_VSAR-Tools_xxx/bin/build/config.js. (where xxx is a current VSAR Tools version) this file contains:

- port to the Envoy service
- refresh time
- material settings (range, advanced) for chroma keyer

Envoy service configuration

VSAR Web expects the Envoy service to be on the same machine.

Envoy works as proxy for VSAR Web, it is a third party tool, more about Envoy proxy on (<https://www.envoyproxy.io/>)

Configuration for Envoy service is located in the PRIME VSAR Tools installation folder (mentioned above) bin\envoy.yaml . Inside the config section vsar_controller_service there is an ip address and port that should be set to the machine that has VSAR Controller service installed.

VSAR Controller service configuration

VSAR Controller allows VSAR Web to run commands on multiple VSAR Renderers, this allows the division of work between multiple machines.

When adding new VSAR to VSAR Controller

1. Make a copy of the Unreal project
2. (this is needed only if project are on the same machine) Change the port in the project files Config\DefaultMithril.ini (create the file if it doesn't exist) and entry example:
[Script/Mithril.MtGrpcHandler]
Address=localhost:50051
3. Add new VSAR to VSAR Controller configuration located in PRIME VSAR Tools installation folder bin\config\config.ini

- a. add name of the VSAR to VSAR_NAME_LIST
example:
[VSAR_NAME_LIST]
VSAR_LIST=MY_VSAR,NEW_VSAR
- b. add entry with the suffix "_URL"
example:
[NEW_VSAR_URL]
VSAR_IP=127.0.0.1
VSAR_PORT=50051
VSAR_POOL=1
VSAR_ENABLED=1

PRIME VSAR

Multiple PRIME VSAR versions can be installed on the same machine, there is no need to uninstall a previous version prior to installing a new one. Warning: it is recommended to uninstall any previous version prior, if expecting to work with only the last one.

- 1) Log in to the Chyron Download Area with your username and password, and search for the PRIME VSAR product.

The PRIME VSAR release name includes the following information

- Associated VSAR version (for example, 2.3.0)
- Associated Epic's Unreal Engine version (for example, 5.6.1)
- Full Build or Plugin version *

* The Full Build version of VSAR includes the installation of Epic's Unreal Engine; the Plugin or Standalone version requires the user to already have a compatible version of Epic's Unreal Engine installed.

For example, 2.3.0-5.6-plugin refers to

- PRIME VSAR v2.3.0
- Epic's Unreal Engine v5.6.1
- Plugin

- 2) Install PRIME VSAR, by double clicking the .exe file (should look like PRIME_VSAR_2.3.0.xxxx-Setup.exe).
- 3) PRIME VSAR Full Build Destination Location - This is the folder where you want to install the full build of PRIME VSAR. By convention, it's recommended to use the suggested folder.

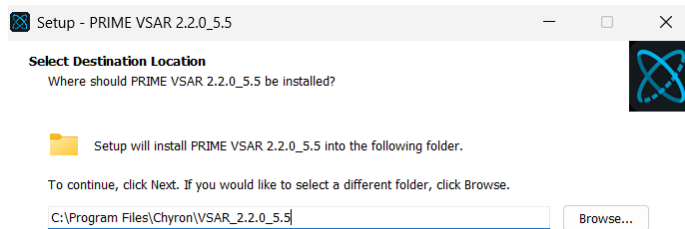

PRIME VSAR Plugin / Standalone Destination Location - This is the root folder for the Plugin's compatible version of Epic's Unreal Engine. VSAR automatically detects if you already have that version installed. If you wish, you can specify a different root directory. The plugin will automatically be installed in rootfolder/Engine/Plugins/Chyronhego.

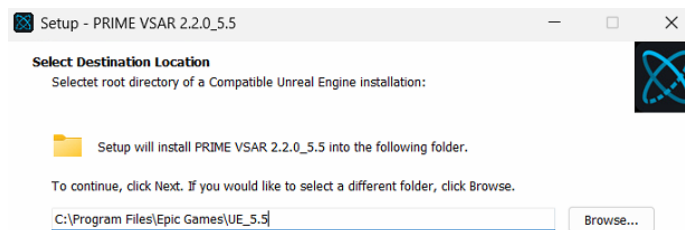

- 4) Follow instructions **above**, if Windows Defender prompts for an unrecognized application.
- 5) If not already installed, you may be prompted for .NET Framework 3.5 installation.
- 6) When asked about components you wish to install, install all components shown in the installer except the Prime VSAR Tools if installed in the previous steps, or unless you have a specific reason not to install Prime VSAR Tools.

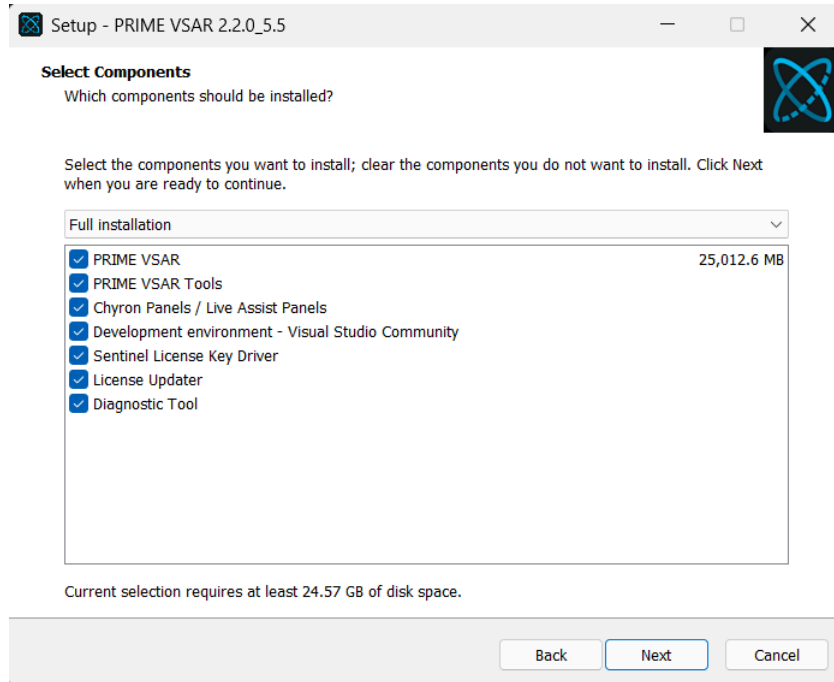

The “Full Installation” includes the following list of components:

- PRIME VSAR: PRIME VSAR Core software
- PRIME VSAR Tools: Additional Tools and Services for remote connectivity
- Chyron Panels / Live Assist Panels: Control Panel application *
- Development environment: To work with nDisplay and Switchboard
- Sentinel License Key Driver: Driver for the USB Dongle License *
- License Updater: Chyron’s license manger *
- Diagnostic Tools: Debug purposes

* Can be downloaded from Chyron’s Download Area and installed separately

To update PRIME VSAR only, we recommend selecting the "Compact Installation" option.

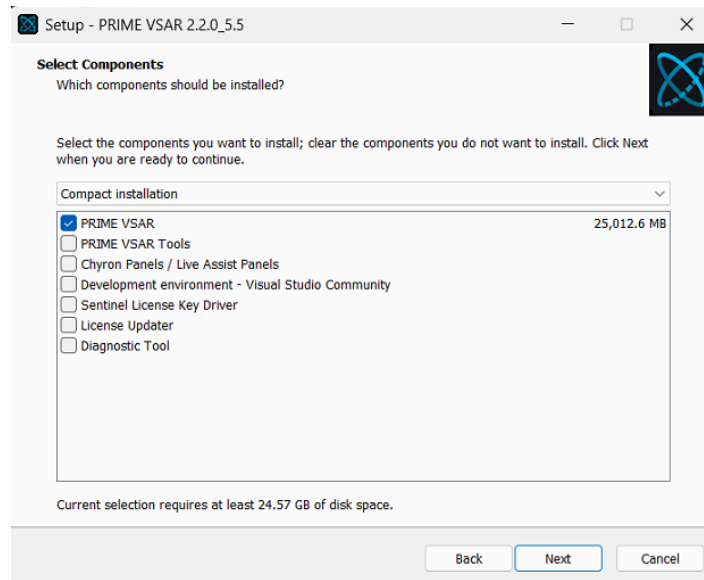

- 7) During the installation process of the Chyron Panels (Live Assist Panels), select the Software license option
- 8) When prompted to restart your computer, do so.
- 9) Successful installation

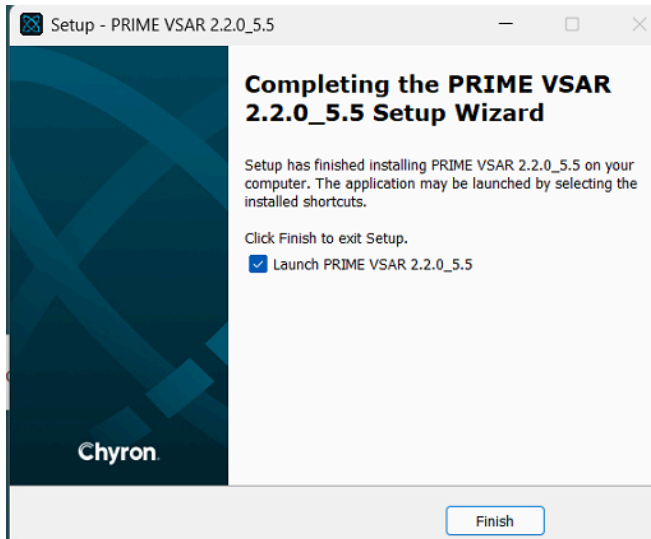

In the case of the Plugin version, it is activated automatically after installation. If the PRIME VSAR Plugin is not activated after installation, you can open your version of Unreal Engine, and under Edit > Plugins, search for "VSAR" to activate/deactivate it manually.

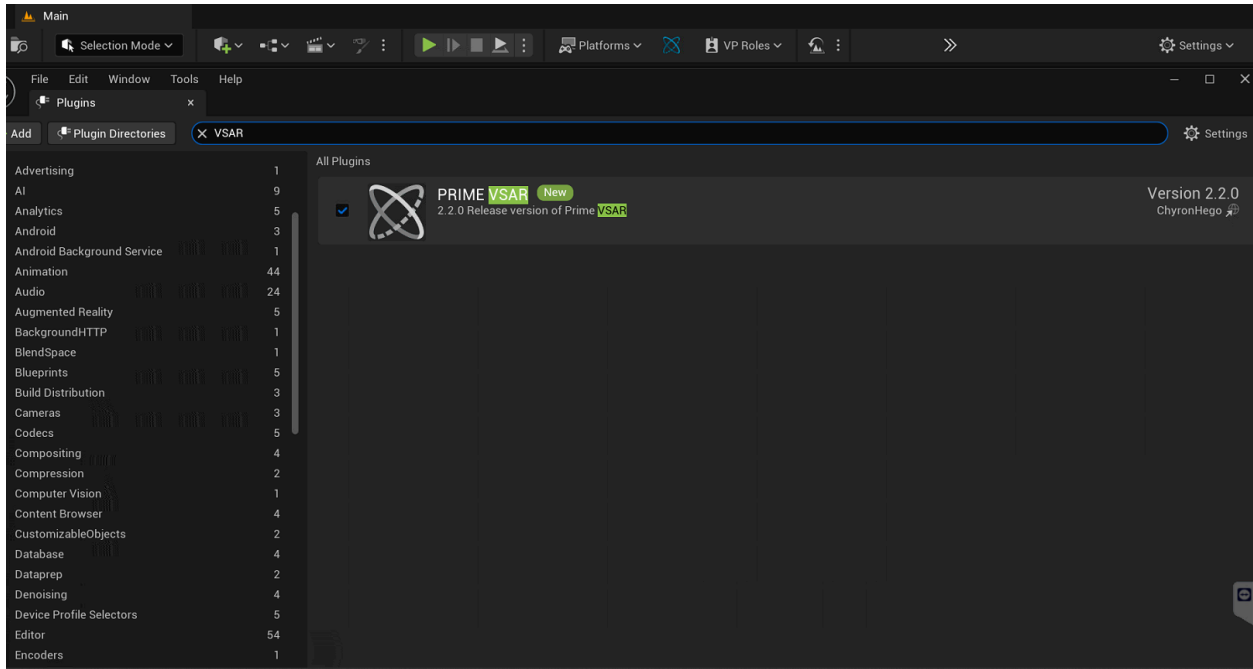

Chyron Panels (Live Assist Panels)

The Chyron Panels (Live Assist Panels) web server has to be started manually by clicking on the LIVE Assist Panels Desktop shortcut.

- Run it to start the web server. You should get the following output:

```

Administrator: Windows PowerShell
C:\Program Files\ChyronHego\LIVE Assist Panels>node index.js
Starting Live Assist Panels - Version 2.8.1
ProcessManager: Creating new Process with module: liveassistpanels
ProcessManager: Creating new Process with module: devicemanager
ProcessManager: Creating new Process with module: backupper
ProcessManager: Creating new Process with module: sysmonitor
ProcessManager: Creating new Process with module: folderwatcher
ProcessManager: Creating new Process with module: ruleengine
ProcessManager: Creating new Process with module: databinder
ProcessManager: Creating new Process with module: virtualdevices
liveassistpanels: Started webservice at port: 80
  
```

- Open Chrome and type in the following URL to open the Panel web page: <http://localhost>. Login default credentials are admin / adminLAP

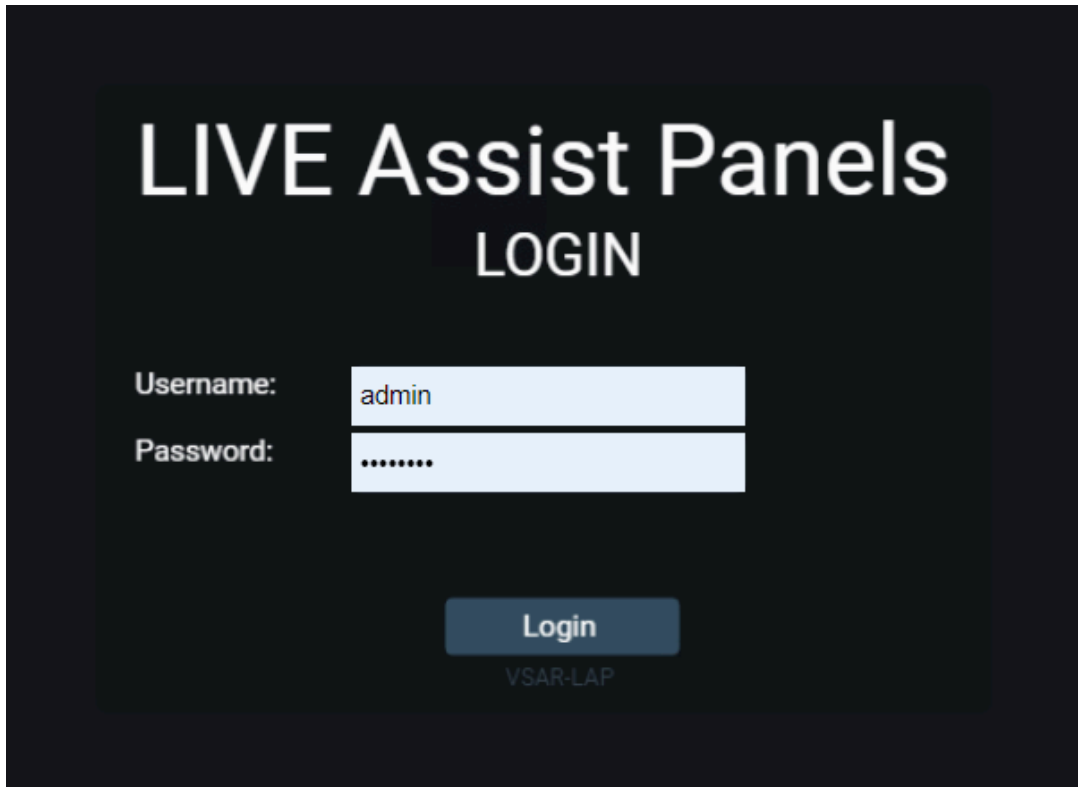

VIDEO SETUP

HAL Video Setup

HAL stands for Hardware Abstraction Layer. It is a common interface to video I/Os for Chyron products (PRIME, ...).

HAL can support different manufacturer boards (called Interface). The inputs and outputs are configured through an Xml file.

Driver installation

Download and install Matrox drivers `Matrox/HAL_driver_10.3.101`

To register HAL for Matrox, open a CommandPrompt, or Bash in Admin Mode. Navigate to your Prime VSAR distribution, and then get into directory:

```
> cd..."C:\Program  
Files\Chyron\PRIME_VSAR-x.x.x.x\Engine\Plugins\Chyronhego\Mithril\ThirdParty \Hal\lib\x64"
```

Then enter the command:

```
> regsvr32 MvIOHAL.dll
```

If for some reason you need to unregister the dll, run:

```
> regsvr32.exe -u MvIOHAL.dll
```

Matrox Board Connections

This document describes the different possible connections of Matrix boards.

for LE5:

HAL Interfaces Configuration

Open the base configuration file

<InstallationDirectory>Engine/Plugins/Chyronhego/Mithril/Config/BaseMithril.ini, you can then activate and deactivate interfaces by changing the lines:

```
[/Script/HalMedia.Hal]  
bInterfaceMatroxEnabled=true  
bInterfaceDeltacastEnabled=false
```

Note that interfaces are evaluated in the upper order. This means that in the Xml configuration file, the first board will be a Matrox board (if any), and then a Deltacast board (if any).

Note that the Deltacast interface is not designed for production.

HAL.xml: Video I/O Streams Configuration

Video Streams are configured in the xml file: %LOCALAPPDATA%/Chyronhego/Fresh/HAL.xml.

Hal.xml configuration file is loaded when PRIME VSAR starts; it allows configuring the genlock, inputs and outputs of the different video boards present on the machine. So whenever you edit this file, you need to restart PRIME VSAR.

⚠ When you change video format in Hal.xml from 25/50 fps to 29.97 VSAR needs to be restarted twice, in order for the change to take effect on the Matrox. This is a known issue.

Syntax

```
<halconfig>
```

```
<board>
```

```
<genlock standard="XXX" source="XXX" input="0"/>
```

```
<output standard="XXX" enabled="true" haskey="false" hphase="0" vphase="0" fifo="3" 4k2si="false"  
tcpcesium="false" cesiumip="127.0.0.1" cesiumport="22222">
```

```
</output/> ...
```

```
<input standard="XXX" enabled="true" haskey="false" fifo="3" timeout="50" "useassync"="false">
```

```
</input/> ...
```

```
</board>
```

```
<board> ... </board>
```

```
</halconfig>
```

Available types

- Available standards for <genlock> <output> and <input> tags are:
 - S259M_NTSC,
 - S259M_PAL,
 - S274M_1080i_59,
 - S274M_1080i_60,
 - S274M_1080i_50,
 - S274M_1080p_59,
 - S274M_1080p_60,
 - S274M_1080p_50,
 - S274M_1080p_29,
 - S274M_1080p_30,
 - S274M_1080p_25,
 - S296M_720p_50,

- S296M_720p_59,
 - S296M_720p_60,
 - S4K_2160p_25,
 - S4K_2160p_29,
 - S4K_2160p_30,
 - S4K_2160p_50,
 - S4K_2160p_59,
 - S4K_2160p_60,
 - SFILM_720p_23,
 - SFILM_720p_24,
 - SFILM_1080p_23,
 - SFILM_1080p_24,
 - SFILM_2160p_23,
 - SFILM_2160p_24
 - Boolean values accept “true|1” and “false|0”
- Note: formats in red have known issues and may not work properly

<genlock>

Available genlock source are: internal|analog|input.

- In internal mode, the board is not genlocked to an external signal.
- In analog mode, the genlock is received on the dedicated Sync BNC.
- In input mode, the genlock is taken from the SDI video input. Input attribute is only relevant when source is set to input.

<output>

If enabled is set to “false” the output will be disabled. Using this you can configure eg.: that the 1st connector is disabled and that you want to use 2. connector only.

If haskey is true, the output will be set in Fill+Key; if set to false, the output will be Fill only. Note that if haskey is enabled. As key is generated, it will be generated automatically into another output connector.

⚠ when haskey=false there is color conversion in place that can result in worse chrominance resolution, for the highest resolution we recommend to use haskey=true

fifo is the number of frames buffered on the video device; there are two working modes:

- FIFO Mode: In fifo mode, frames computed by VSAR are pushed on the output connector; there can't be more than fifo buffers on the output queue. Setting a value of minimum 2 is required, 3 is recommended. In this mode, VSAR cannot guarantee that Cesium data will be properly in sync with the real camera.
- Delay Mode: In Delay mode, a fixed delay is guaranteed between a given input on the Matrox board, and a given output. For example, 6 frames can be guaranteed between SDI input 0 and output 2. To use this mode. You need to select an input as the 'reference delay' input (see useassync in <input> below).

hphase and vphase set the video phase of each output separately (they can be edited in the GUI, but they are currently not reported in the xml file).

If 4k2si is true then the 4K signal is transmitted in 2 sample interleave format; otherwise four quadrant splits are used. Note: this feature may not work on some Matrox cards, use mvConnectorConfig (see below) to configure 2SI.

If tcpcesium is true then tcp messages will be sent to cesium to genlock the UdpGenlock Cesium drivers. This value is usually set to false in standard operation. cesiumip and cesiumport allow you to set the Cesium you want to send sync messages to.

If HDR is true the camera rendering is done in larger color resolution (16f) and then send using packed 10b signal (YCrCb_422_10b) to output

Valid Output arguments:

- | | | |
|--------------|-------------------|------------------------------------|
| ● standard | - Standard string | example: standard="S274M_1080i_59" |
| ● haskey | - Boolean | example: haskey="true" |
| ● enabled | - Boolean | example: enabled="true" |
| ● fifo | - Integer | example: fifo="3" |
| ● hphase | - Integer | example: hphase="0" |
| ● vphase | - Integer | example: vphase="0" |
| ● tcpcesium | - Boolean | example: tcpcesium="true" |
| ● cesiumip | - IP string | example: cesiumip="127.0.0.1" |
| ● cesiumport | - Port string | example: cesiumport="4300" |
| ● 4k2si | - Boolean | example: 4k2si="true" |
| ● hdr | - Boolean | example: hdr="true" |

<input>

Input has the same attributes as output.

timeout is the duration (in ms) after which a video source is considered missing.

useassync is a boolean used to select an input source as the 'Delay mode' reference. If several inputs have the tag useassync set to true, then only the last one is considered as the sync source.

⚠ When using useassync, VSAR main thread is "locked" to the input, meaning that when input is not available VSAR can get stuck.

⚠ When using useassync input in MediaPlayer it is possible on close of the source that output may drop up-to 2 frames, we recommend in production to keep it either opened or closed.

Valid Input arguments:

- | | | |
|-------------|-------------------|------------------------------------|
| • standard | - Standard string | example: standard="S274M_1080i_59" |
| • haskey | - Boolean | example: haskey="true" |
| • enabled | - Boolean | example: enabled="true" |
| • fifo | - Integer | example: fifo="3" |
| • timeout | - Integer | example: timeout="50" |
| • useassync | - Boolean | example: useassync="true" |

Notes/Troubleshooting:

- When a new "output" (resp. "input") is parsed the previously parsed output (resp. "input") is copied to the new one. This allows the user not to copy all the attributes on each line.
- This is also true for the "standard" attribute of genlock, which will be copied to the next input and output lines.
- The tcpcesium is reset to false when a new output is built.
- For Matrox, if you change the framerate (eg: 50->59, or 59->60) then you may have to restart twice PRIME VSAR before it's taken into account.
- For Matrox, it seems that changing haskey needs a reboot. In fact haskey="true" -> haskey="false" seems to work, but the other way seems very challenging. The same applies for 4K outputs.

- If you have more <output> or <input> declared in the xml file than the actual hardware has, they are silently ignored. Thus it's harmless to leave extra <output> or <input> lines.

Delay Mode Notes:

In Delay mode, you need to have set at least one input with “useassync”=“true” (see Example4 below). This input is called ‘delay reference input’.

- If an input has the “useassync” tag set, all the outputs will be considered as configured in “Delay Mode”, thus their fifo attribute will silently be set to 0.
- You need to have the genlock in sync with the ‘delay reference input’. If you use “source”=“analog” then the analog genlock should be in sync with the ‘delay reference input’. Alternatively, you can set “source”=“input” “input”=“XX” where XX is the index of the ‘delay reference input’, starting at 0 (the first input has index 0, the second index 1, and so on).

To tune the delay between the output and the ‘delay reference input’, get in VSAR Control Panel > Video Output > Outputs > Frame Delay. Frame delay is set independently for each output. The default is 6.

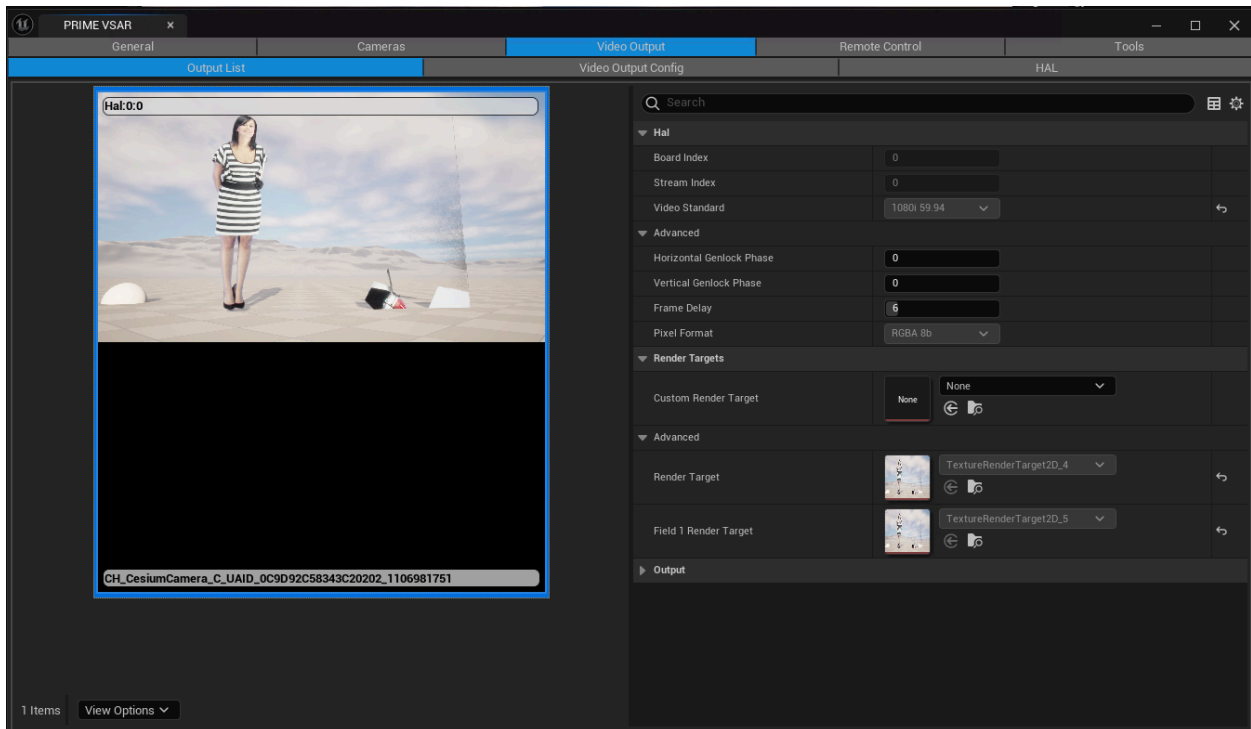

Matrox I/O reconfiguration

If you need to reconfigure the number of video inputs and outputs: open a command prompt with Admin rights:

```
> cd "C:\Program Files\Matrox DSX-TopologyUtils\drivers"
```

To get the list of commands (optional)

```
> mvConnectorConfig.exe -help
```

To get the Matrox Card Serial Number

```
> mvConnectorConfig.exe list
```

To display the card's current configuration

```
> mvConnectorConfig.exe -ShowCurrent -sn=<Matrox Card Serial Number>
```

To re-affect the number of video inputs and outputs (x and y values respectively)

```
> mvConnectorConfig.exe -<x>in<y>out -sn=<Matrox Card Serial Number>
```

The last command takes a while to execute, then you have to reboot the machine.

Example usage for reconfiguration of 4 spigot card from 2 in 2 out into 3 in 1 out:

```
For example:
./mvConnectorConfig.exe list
./mvConnectorConfig.exe -ShowCurrent -sn=A123456
./mvConnectorConfig.exe -4in4out -Silent
./mvConnectorConfig.exe -8in0out -sn=A123456
./mvConnectorConfig.exe -FlowRouting=alt -sn=A123456
./mvConnectorConfig.exe -FlowRouting=alt -4in0out -sn=A123456
./mvConnectorConfig.exe -2SI=on -sn=A123456

ChyronHego@DESKTOP-3T7TCG1 MINGW64 /c/Program Files/Matrox DSX-TopologyUtils/drivers
$ ./mvConnectorConfig.exe list

<< Matrox Connectors Configuration tool >> Tuesday, March 22, 2022 12:25:17
Available hardware:

    0) DSXLE4 S/N=A581423

ChyronHego@DESKTOP-3T7TCG1 MINGW64 /c/Program Files/Matrox DSX-TopologyUtils/drivers
$ ./mvConnectorConfig.exe -ShowCurrent -sn=A581423

<< Matrox Connectors Configuration tool >> Tuesday, March 22, 2022 12:25:42
Current IO Configuration:
    SDI Inputs  = 2
    SDI Outputs = 2

ChyronHego@DESKTOP-3T7TCG1 MINGW64 /c/Program Files/Matrox DSX-TopologyUtils/drivers
$ ./mvConnectorConfig.exe -3in1out -sn=A581423

<< Matrox Connectors Configuration tool >> Tuesday, March 22, 2022 12:26:02

Updating card 0-DSXLE4L/4/100F-S/N A581423
Info: Selected IO Configuration '3in1out' will be applied to the card.
Info: The IO configuration requested is being applied to the card...
```

PRIME VSAR: nDisplay integration

nDisplay integration allows the use of HDMI / DisplayPort output for VSAR with the use of Cesium Camera.

nDisplay Setup

nDisplay Requirements:

- Nvidia Quadro Sync II
- Cat-5 or Cat-6 RJ45 cables. (for multiple machines)
- BNC cable for genlock
- DisplayPort to HDMI convertor (only for HDMI)

Sync setup

Nvidia Quadro Sync II needs to be installed in the PCIe slot on the motherboard and connected with appropriate cable to the Nvidia GPU. for more information see more at [Quadro-Sync-II user guide](#)

The cable should come with the Nvidia Quadro Sync II, Nvidia GPU has the ports for the Quadro Sync II connection at the top; they usually have plastic cover that needs to be removed to uncover the ports and connect the according the [Quadro-Sync-II user guide](#)

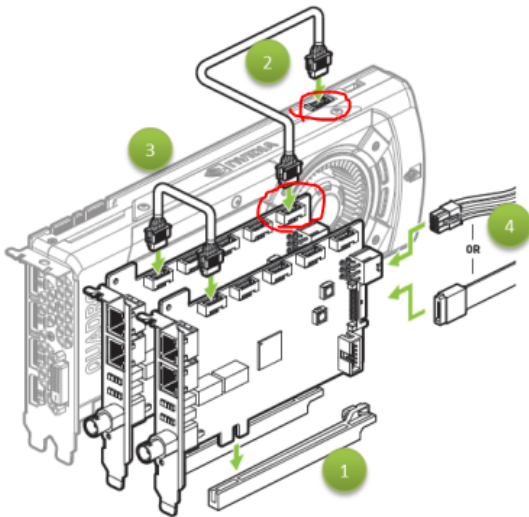

After the cable is properly connected to the GPU. We need to connect the genlock signal using BNC cable to the spigot.

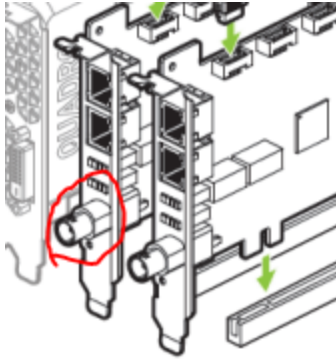

after the connection is correctly connected make sure to install the the Quadro sync II Driver (the link is for windows 11)

For multiple machines:

Frame Lock: connected to the Cat-5 or Cat-6 RJ45 cables according to the [Quadro-Sync-II user guide](#), make sure to use direct connections without any TCP/IP hardware in between. Coming from the master machine going into the client machines.

Or

External Sync only: connect each Nvidia Quadro Sync II to genlock source and set them up all with external sync source.

when properly set-up on master it should say “External Sync signal: Present (Not in use)”

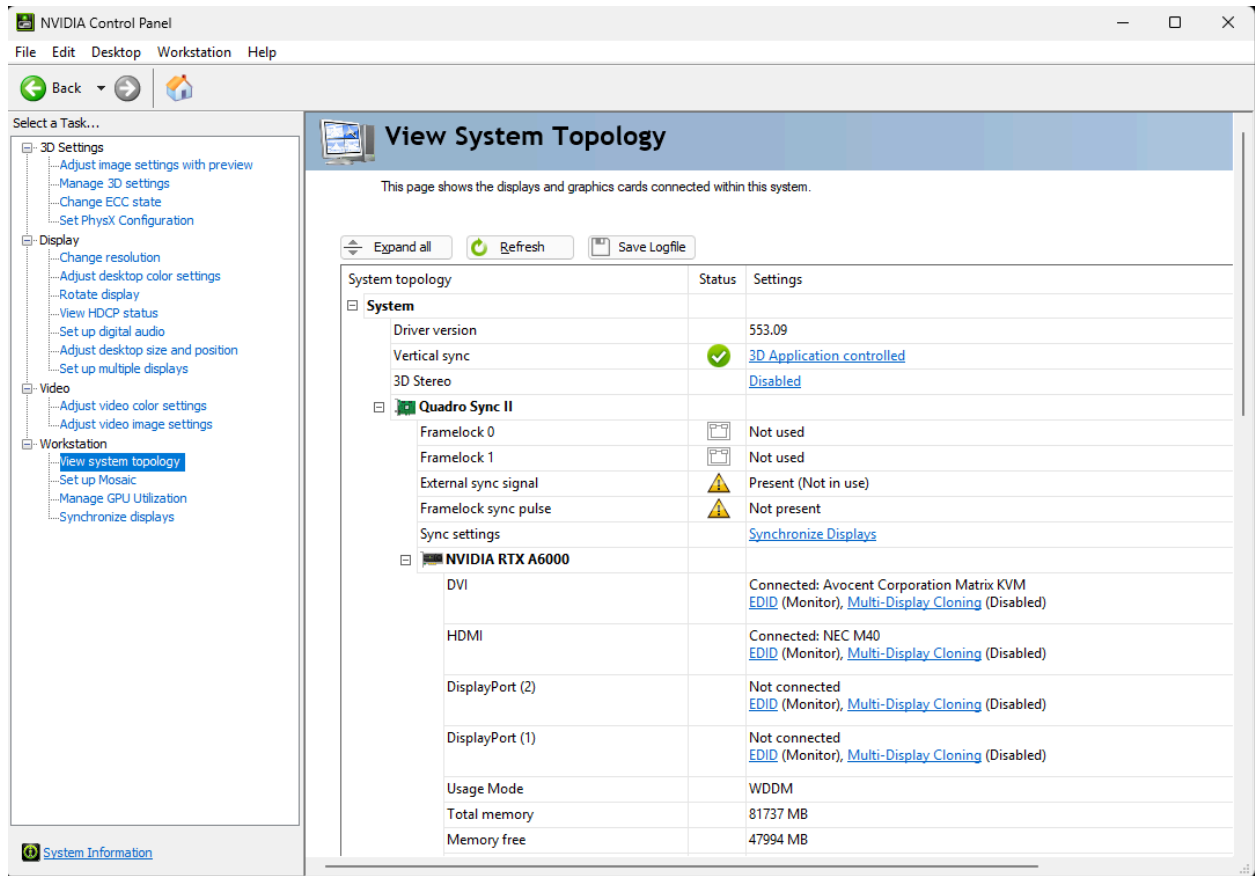

go to Synchronize Displays

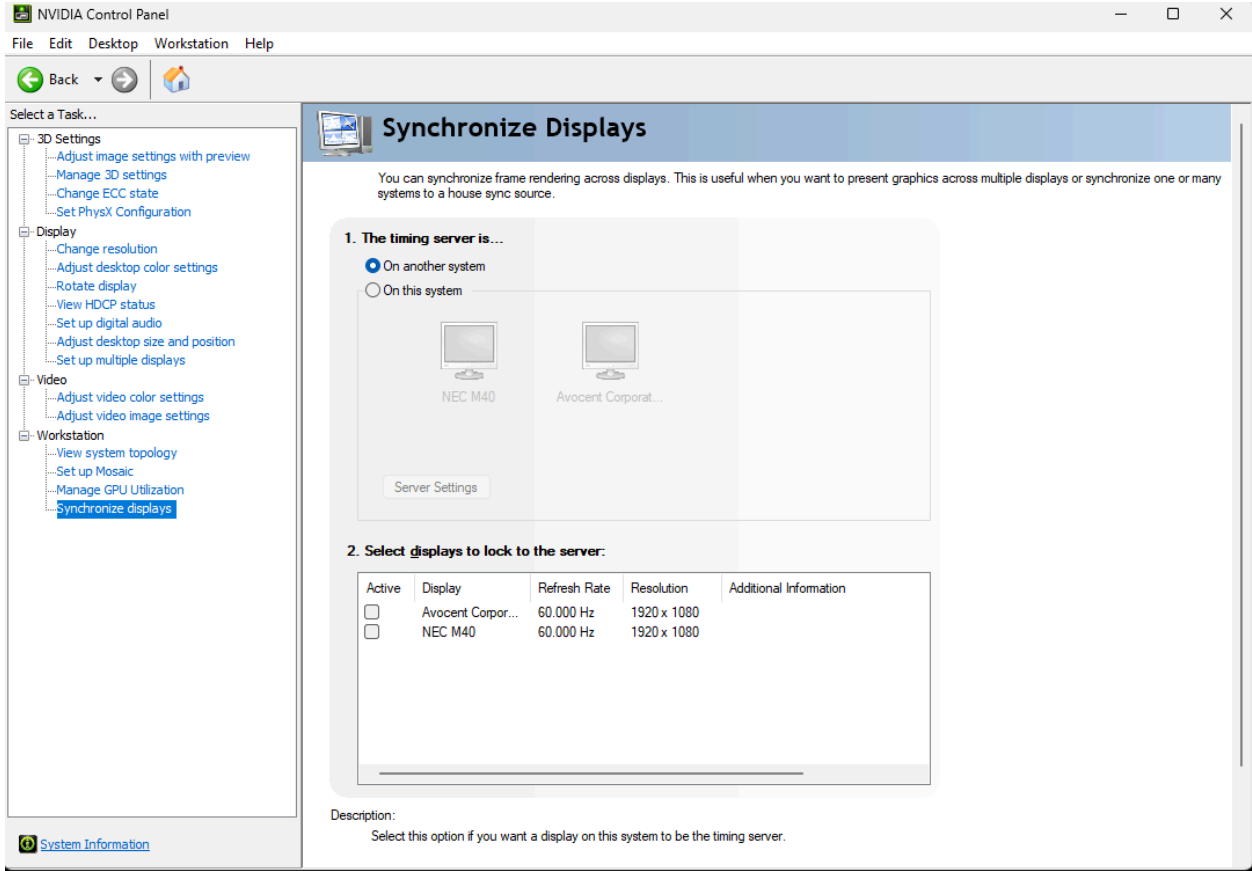

Select On this system

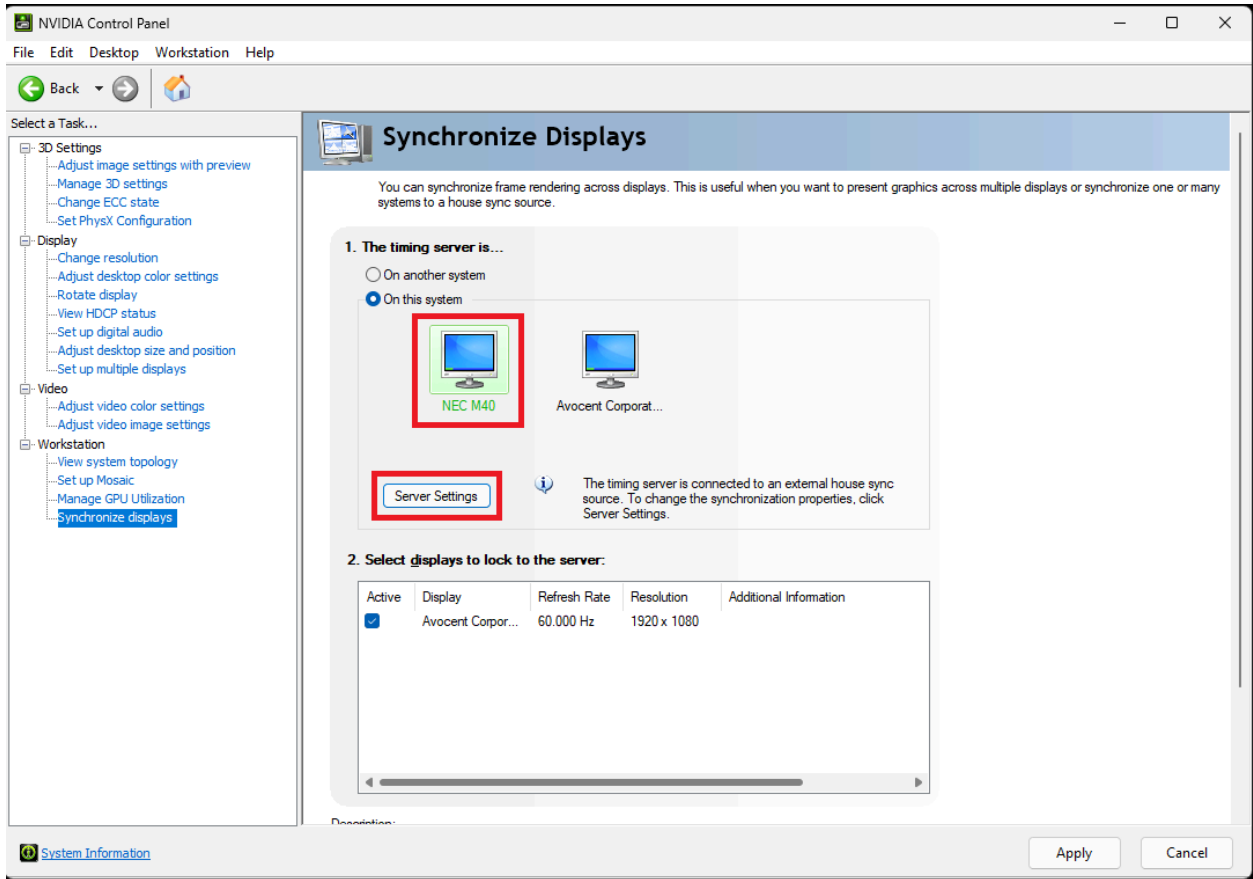

Select the Main Display and click the Server Settings

if you see that the external sync frequency does not match

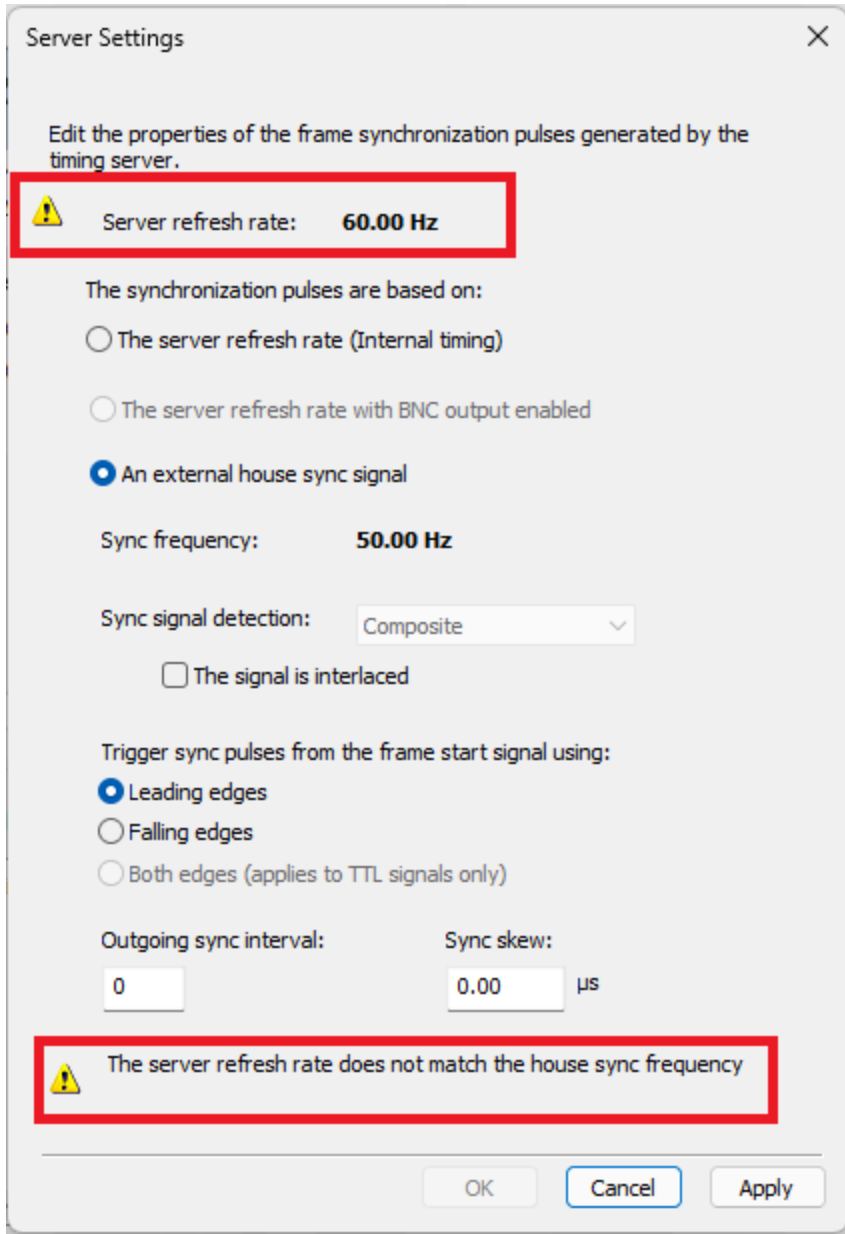

you can fix that by going into change resolution -> refresh rate

⚠ when you experience blinking of the windows try restarting the display

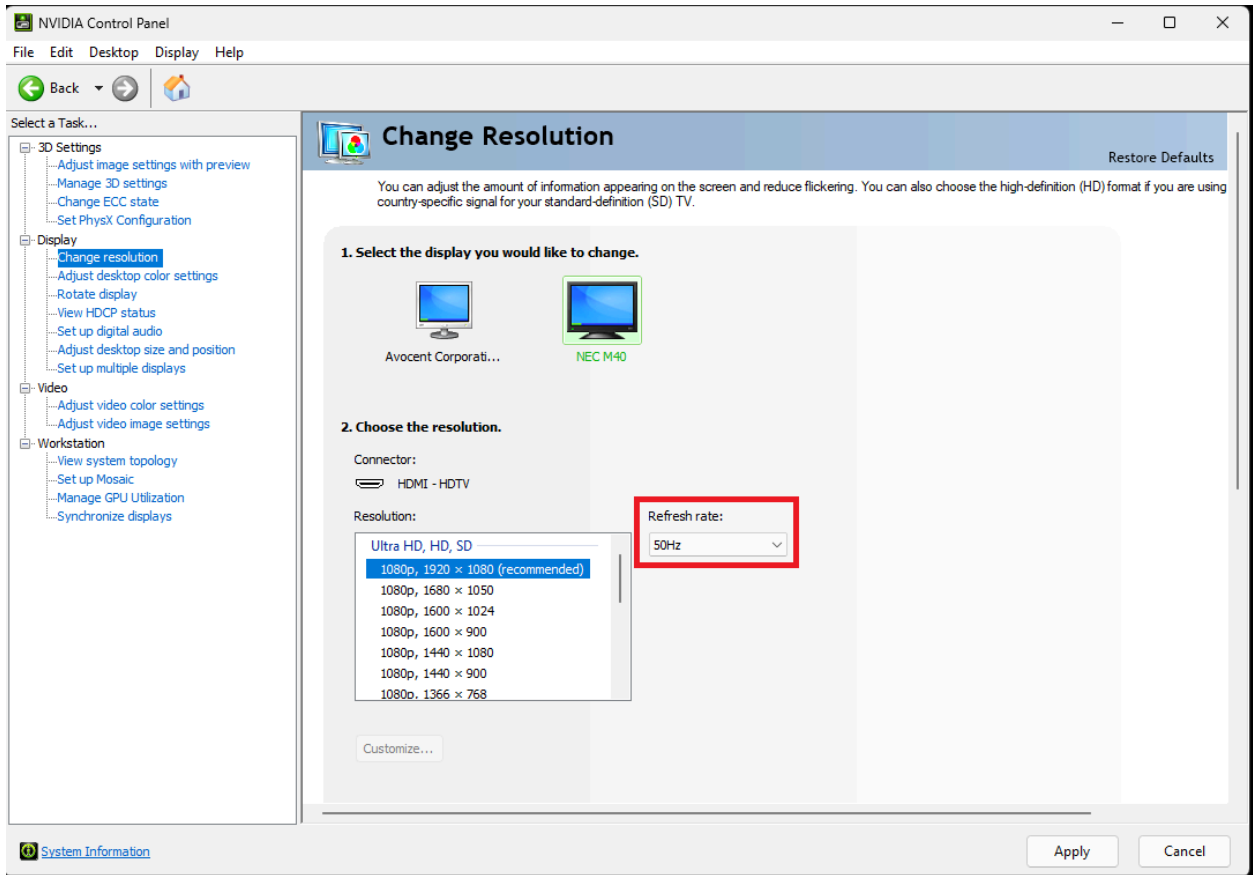

make sure click Apply

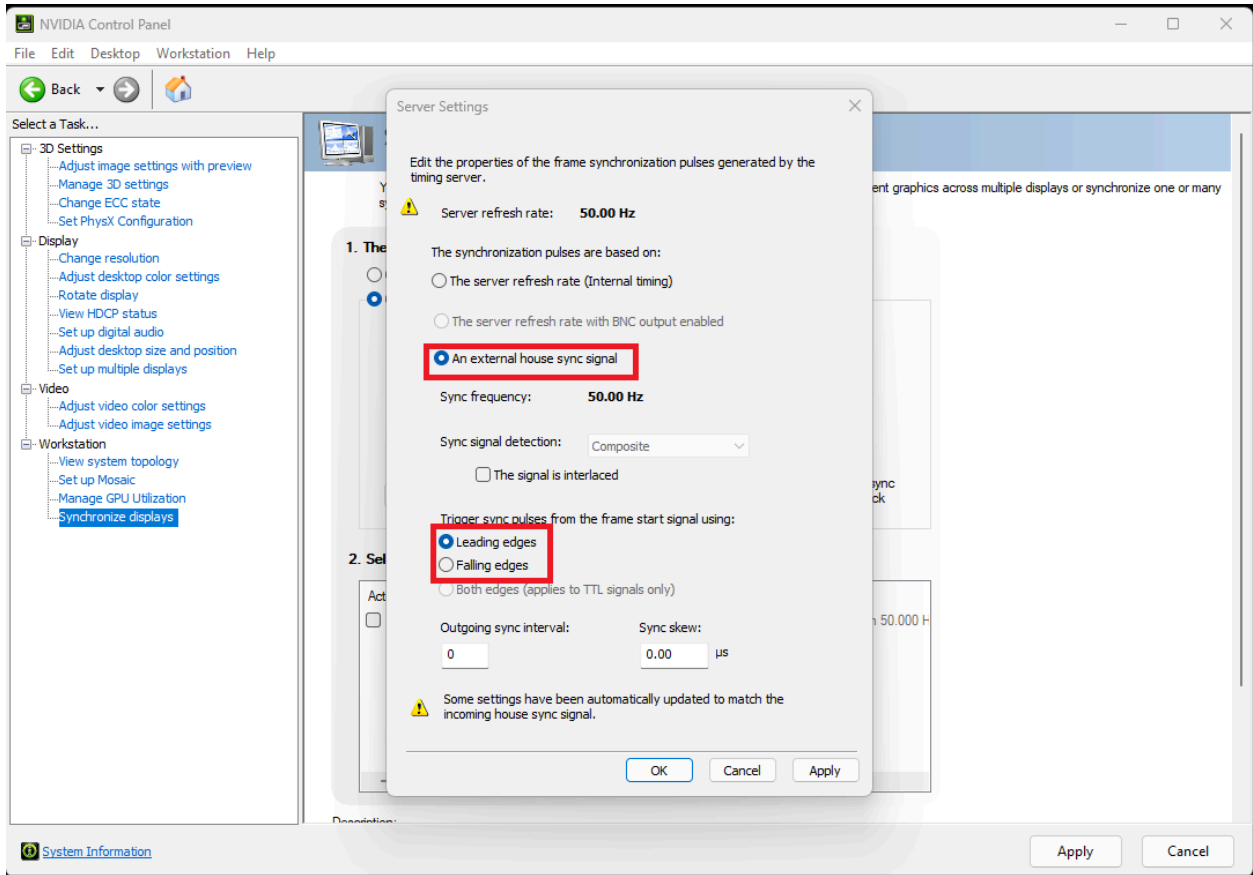

select the An external house sync signal and select the Leading/Falling edges depending on the genlock generator.

click Apply

make sure to confirm the setting

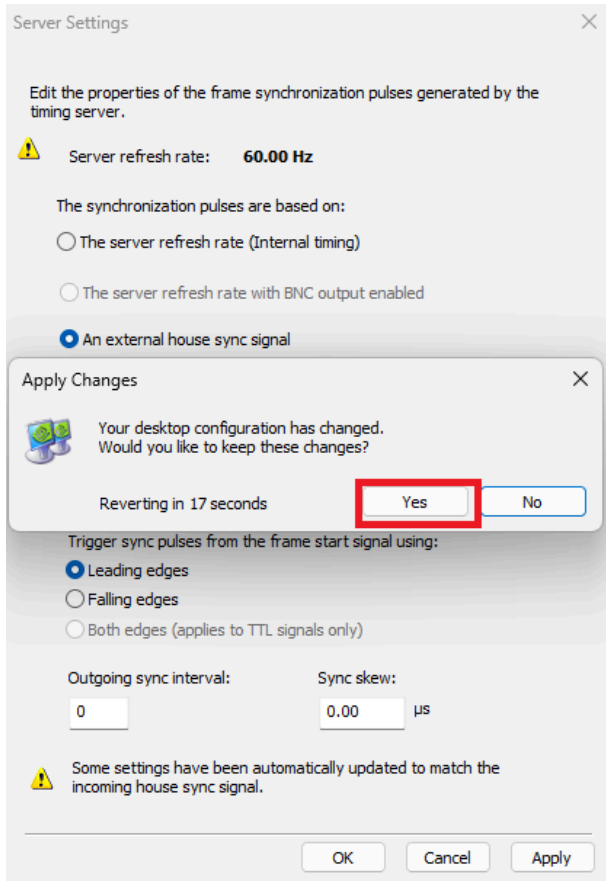

when the genlock is actively in use it should say “External Sync signal: Present (in use)” (may not necessarily mean that all configuration is correct just that it is used)

NVIDIA Control Panel

File Edit Desktop Workstation Help

Back

Select a Task...

- 3D Settings
 - Adjust image settings with preview
 - Manage 3D settings
 - Change ECC state
 - Set PhysX Configuration
- Display
 - Change resolution
 - Adjust desktop color settings
 - Rotate display
 - View HDCP status
 - Set up digital audio
 - Adjust desktop size and position
 - Set up multiple displays
- Video
 - Adjust video color settings
 - Adjust video image settings
- Workstation
 - View system topology**
 - Set up Mosaic
 - Manage GPU Utilization
 - Synchronize displays

View System Topology

This page shows the displays and graphics cards connected within this system.

Expand all Refresh Save Logfile

System topology	Status	Settings
System		
Driver version		553.09
Vertical sync	✓	3D Application controlled
3D Stereo		Disabled
Quadro Sync II (server)		
FrameLock 0	✗	Out
FrameLock 1	✗	Out
External sync signal	✓	Present (In use)
FrameLock sync pulse	✓	Present
Sync settings		Synchronize Displays
NVIDIA RTX A6000		
DVI		Connected: Avocent Corporation Matrix KVM EDID (Monitor) , Multi-Display Cloning (Disabled)
HDMI		Connected: NEC M40 EDID (Monitor) , Multi-Display Cloning (Disabled)
DisplayPort (2)		Not connected EDID (Monitor) , Multi-Display Cloning (Disabled)
DisplayPort (1)		Not connected EDID (Monitor) , Multi-Display Cloning (Disabled)
Usage Mode		WDDM
Total memory		81737 MB
Memory free		47994 MB

System Information

Enable Plugins

Open VSAR in Edit -> Plugins

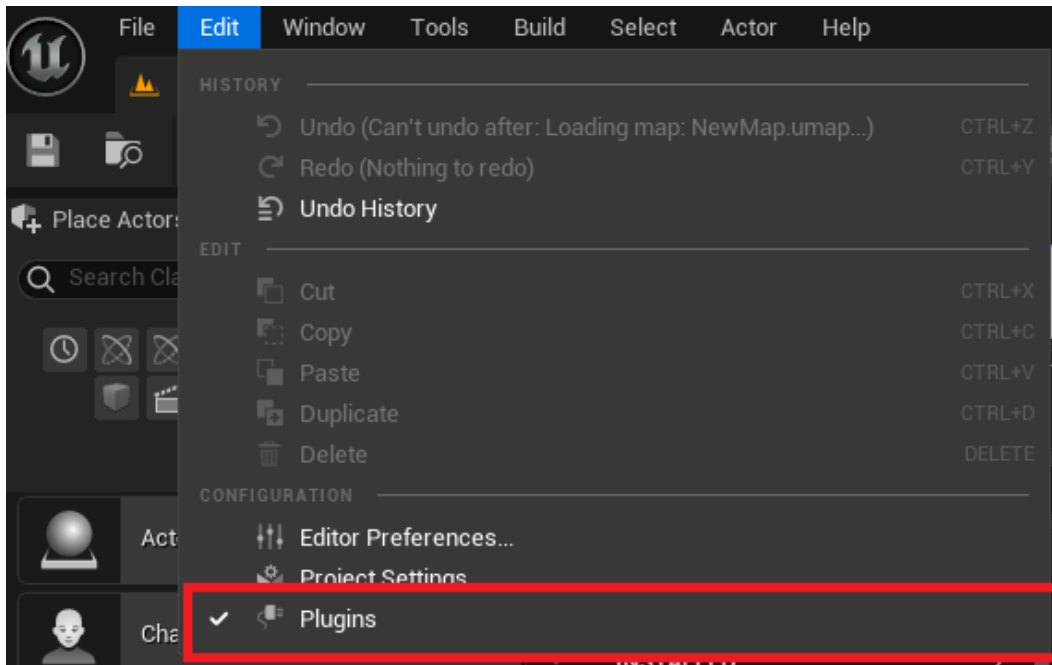

search for nDisplay and enable nDisplay and nDisplay Launch

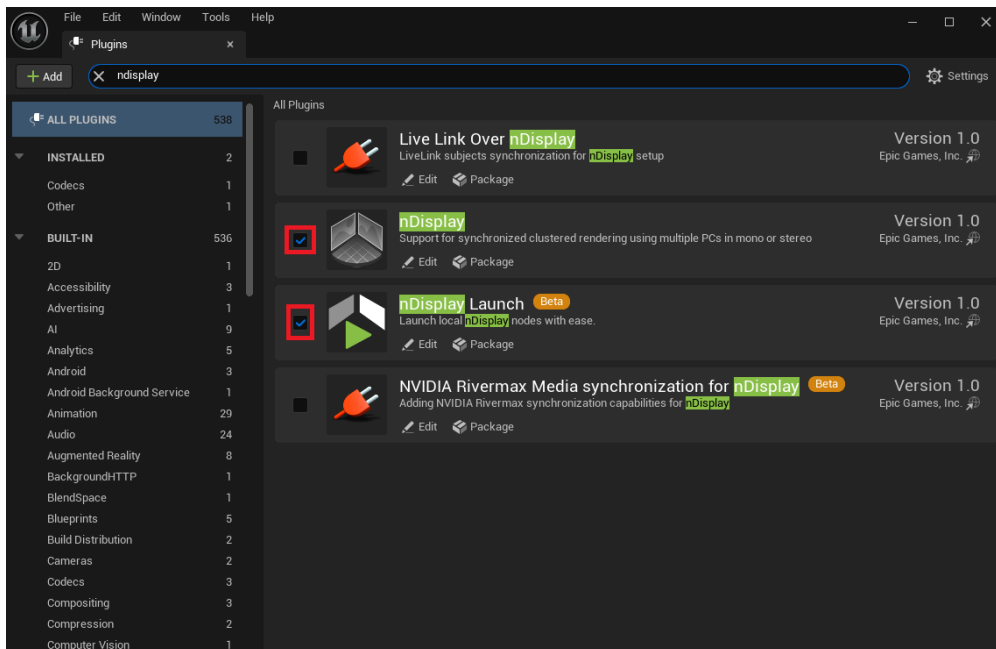

search for switchboard and enable it

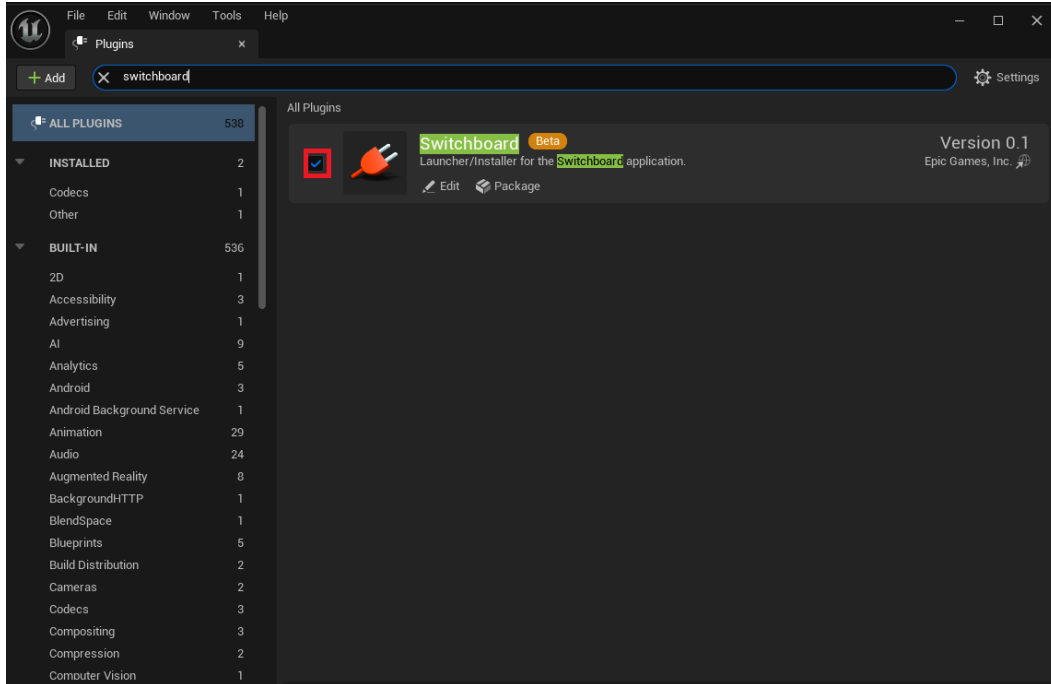

you may need to restart VSAR

Render target

Cesium Camera is using the render target as intermediary between Cesium Camera and nDisplay. Create Render target by Right click in Content browser and select Render target.

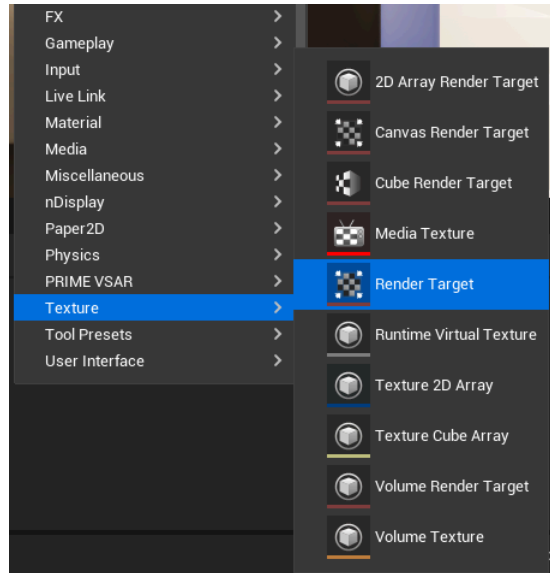

double click on the Render target asset and set the Size X, Size Y to use custom resolution

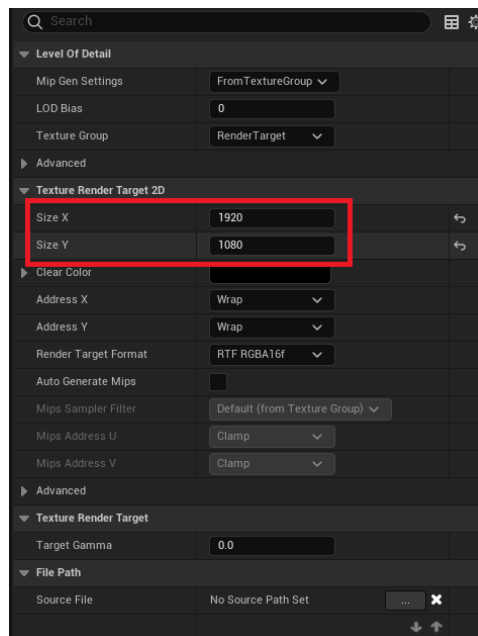

Create one for each Cesium Camera that should have HDMI / DisplayPort as output using nDisplay.

nDisplay config

Create nDisplay config asset in Content browser, Right click in Content browser and select nDisplay config under nDisplay -> nDisplay config

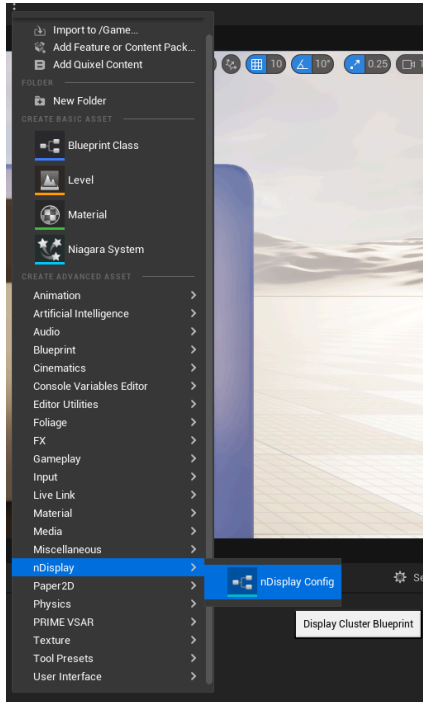

create new config

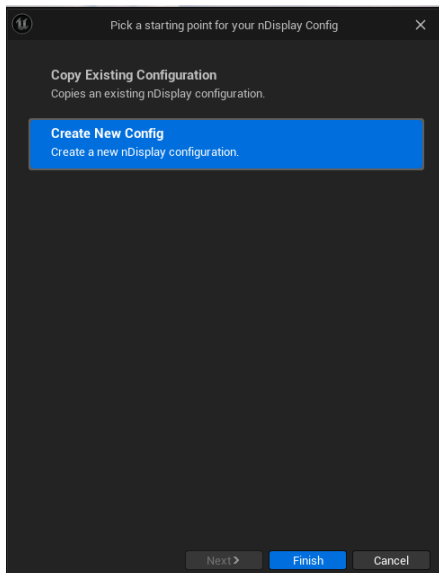

Add New Cluster Node

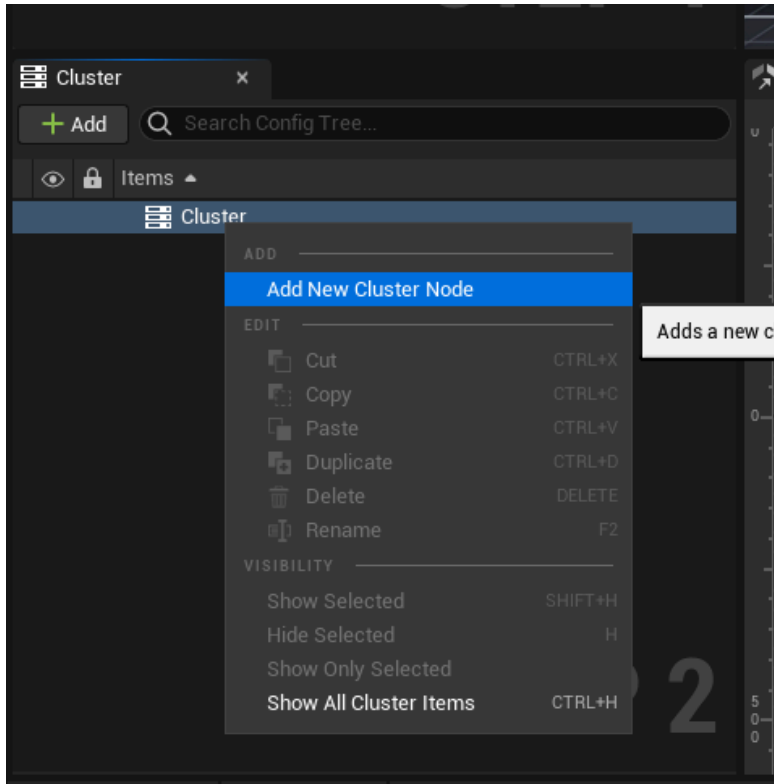

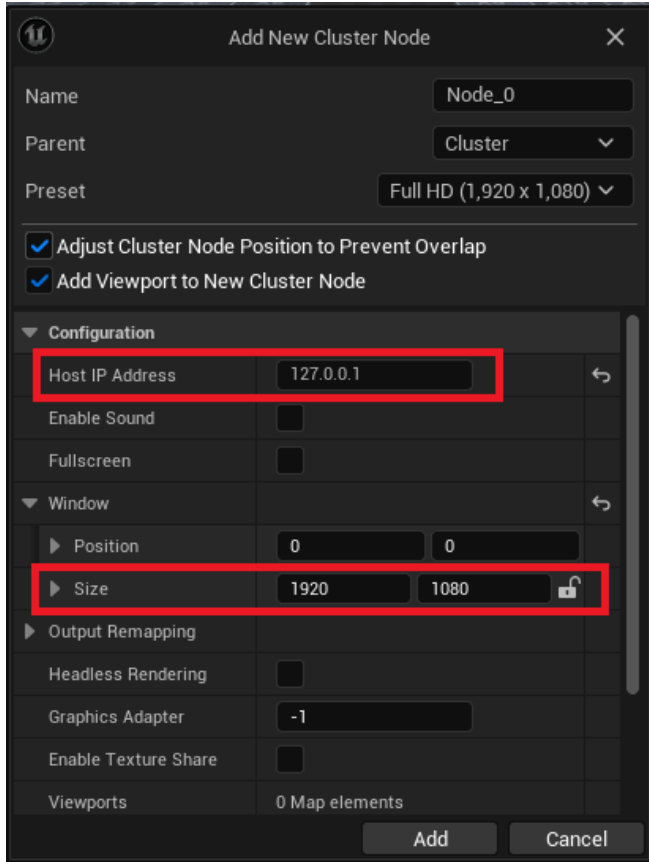

Set the Host IP Address if Cluster Node is not a local host (127.0.0.1). You can set your custom resolution in the Window -> Size, this is the size of all displays connected to the system.

Note: Max size is 8192 x 8192 but it can be increased by DC.OverrideMaxTextureDimension

this should created VP_0

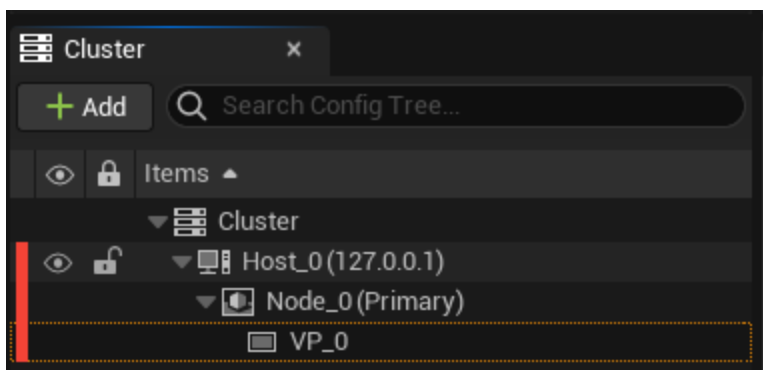

Drag and drop VP_0 to the nDisplayScreen

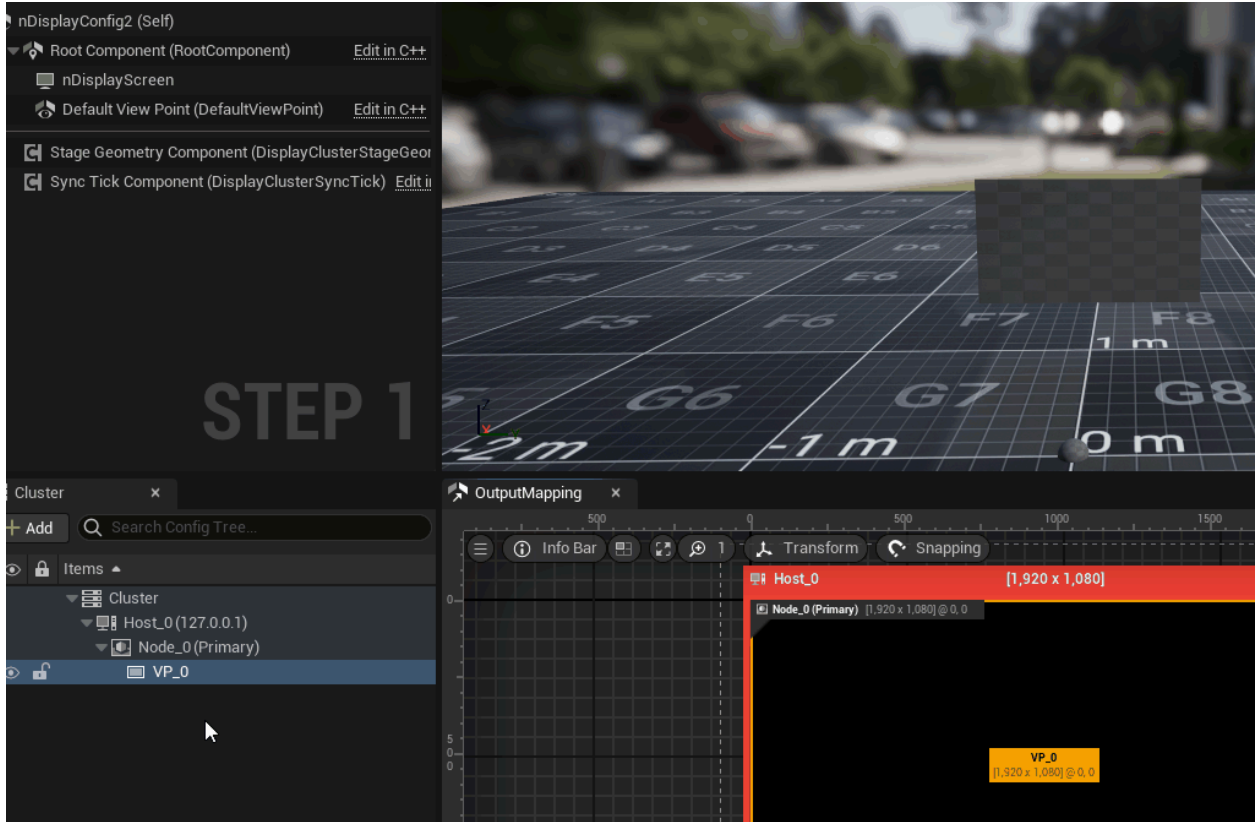

When using custom resolution make sure to adjust the nDisplayScreen size in the details panel under Screen Size -> Size

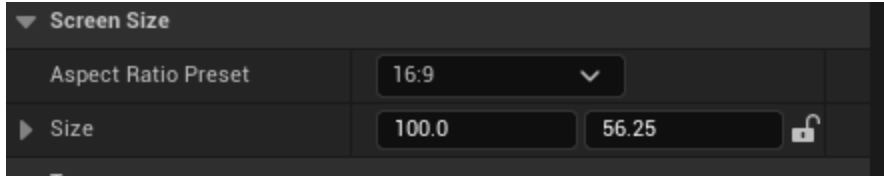

Select the VP_0 in details panel set Replace -> Source Texture to the render target created before and make sure the Enable Viewport Texture Replacement

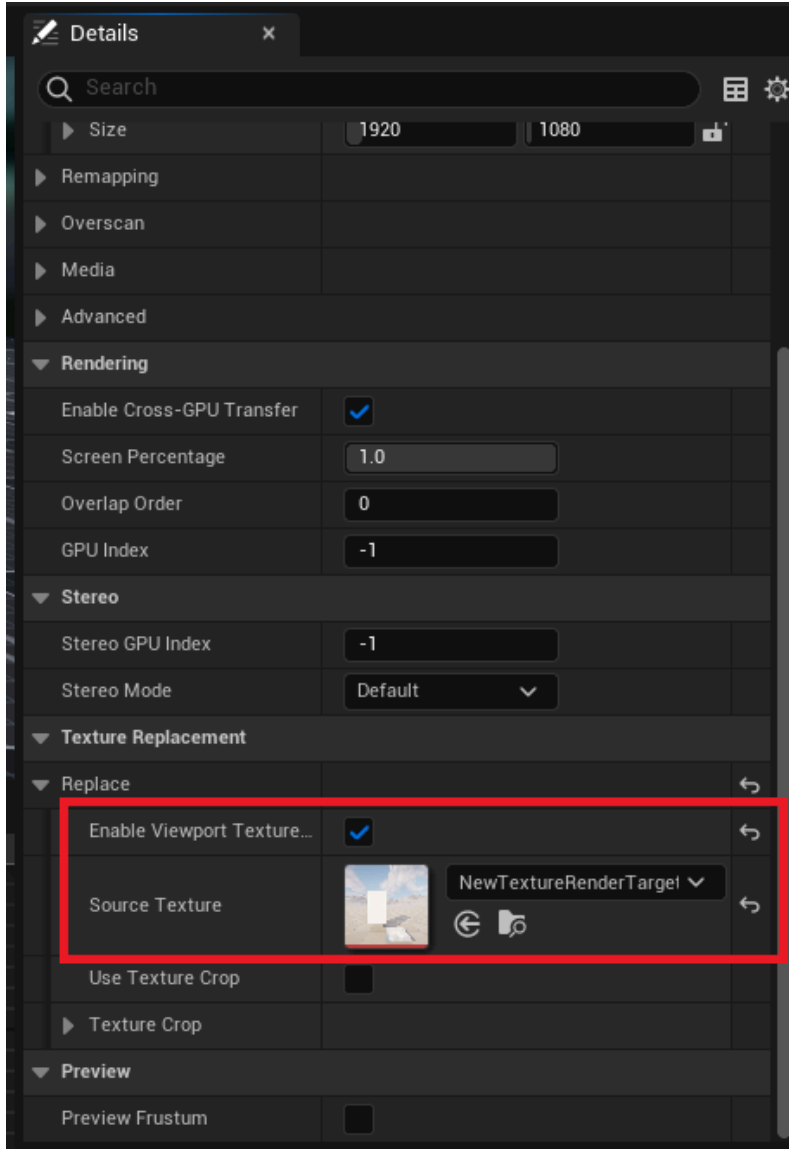

Add second viewport (per node) that the sole purpose of it is to have a valid Viewport due to deferred rendering requiring a valid Viewport (this requirement may be removed in future releases)

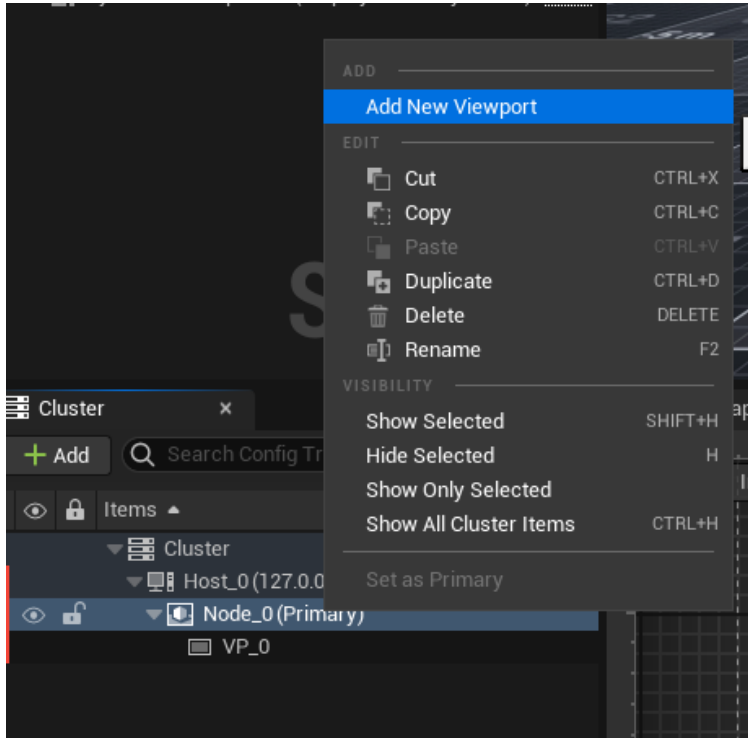

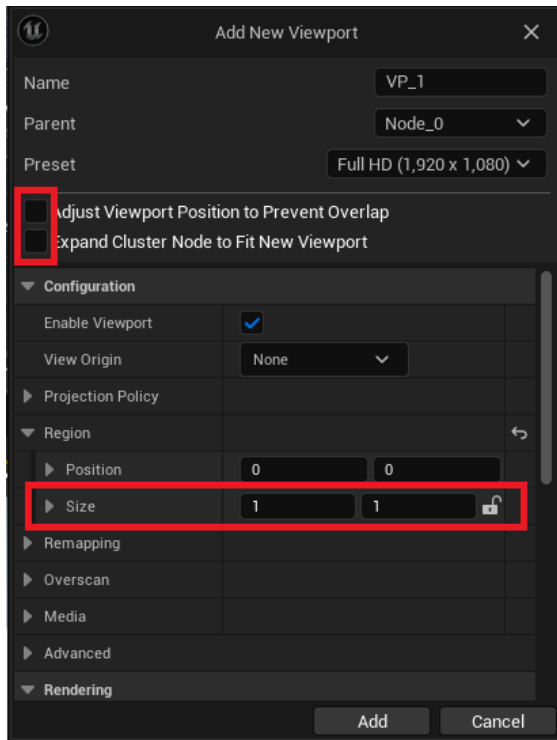

with the size of 1x1, we want the viewport to be as small as possible, and uncheck the adjust Viewport position to prevent overlapping and expand cluster node to fit new viewport.

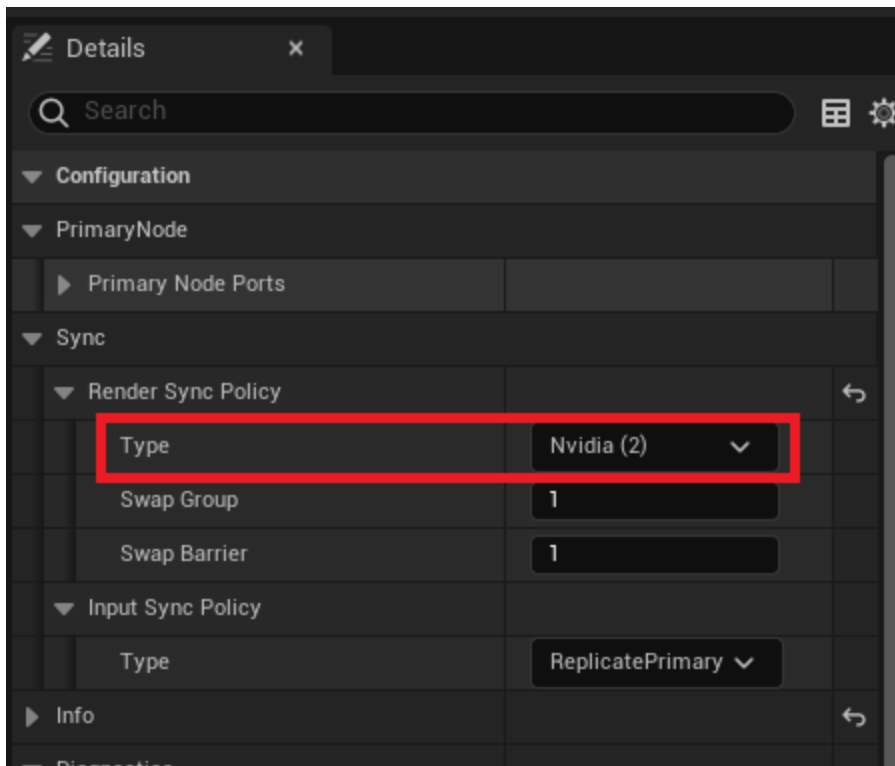

Make sure to also drag and drop the this Viewport on the nDisplayScreen

Select Cluster in details panel under Sync -> Render Sync Policy -> Type select Nvidia (2)



 for the Nvidia sync to work correctly it requires the display resolution to much the display resolution, also it does not work properly when application is out of focused or remote desktop user is connected (example: TeamViewer user is connected).

Save and Compile

drag and drop the nDisplay config asset to scene (level)

Multiple display setup

On system with multiple displays you want to set main Node for Main Display as the nDisplay window(s) appears on the Main Display, for secondary display you want to add additional Node set it up same as the first one and then use the Nvidia mosaic to map it to the proper display.

Interlaced display

If your specific use case requires interlaced output you can enabled that for the display in the Change resolution -> Customize

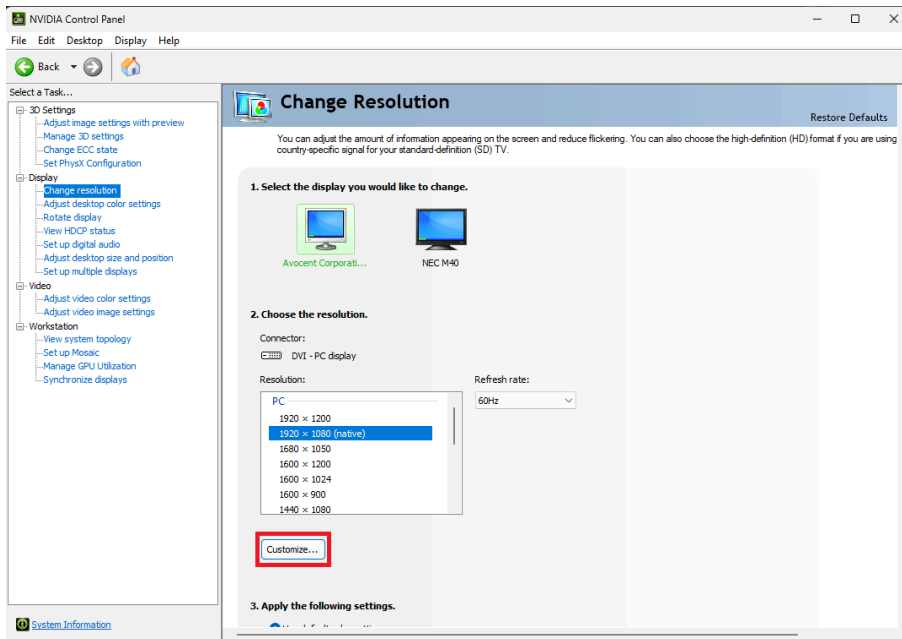

Click the Create Custom Resolution...

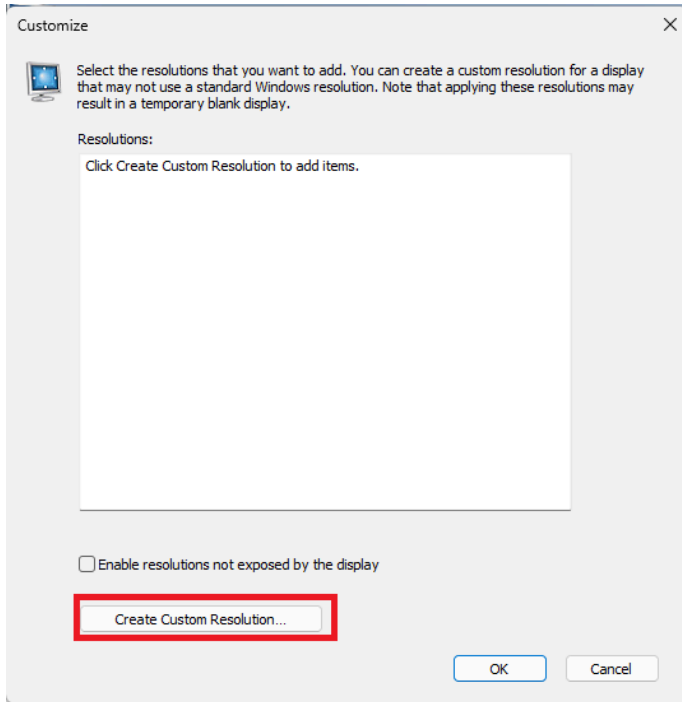

Accept the Legal Disclaimer (make sure you know what you doing)

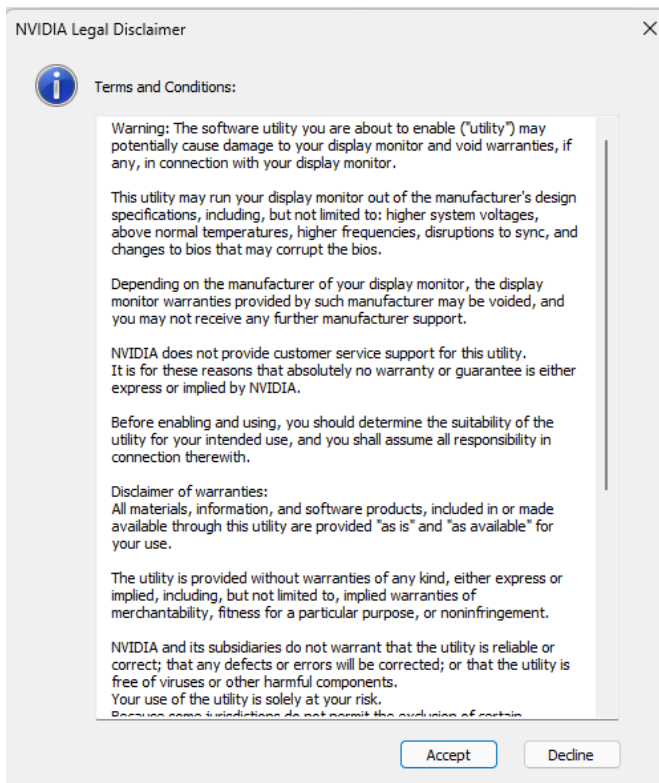

Select the correct display

In the Scan type you can select Interlaced

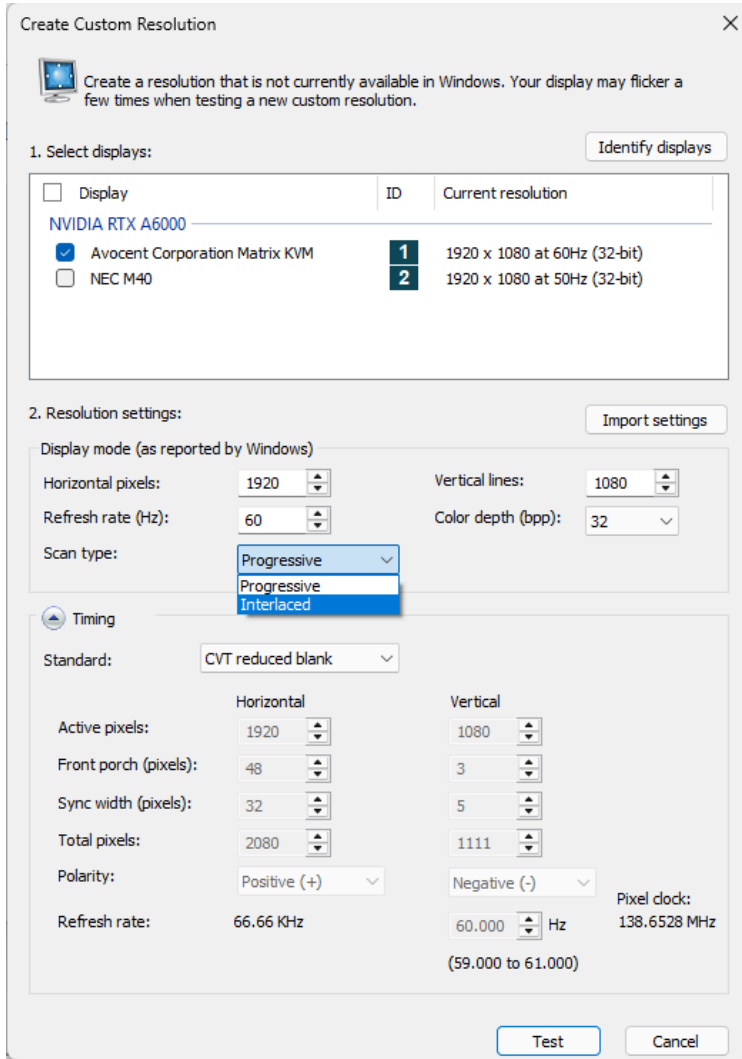

Cesium Camera Output

in PRIME VSAR config add Render Target Output

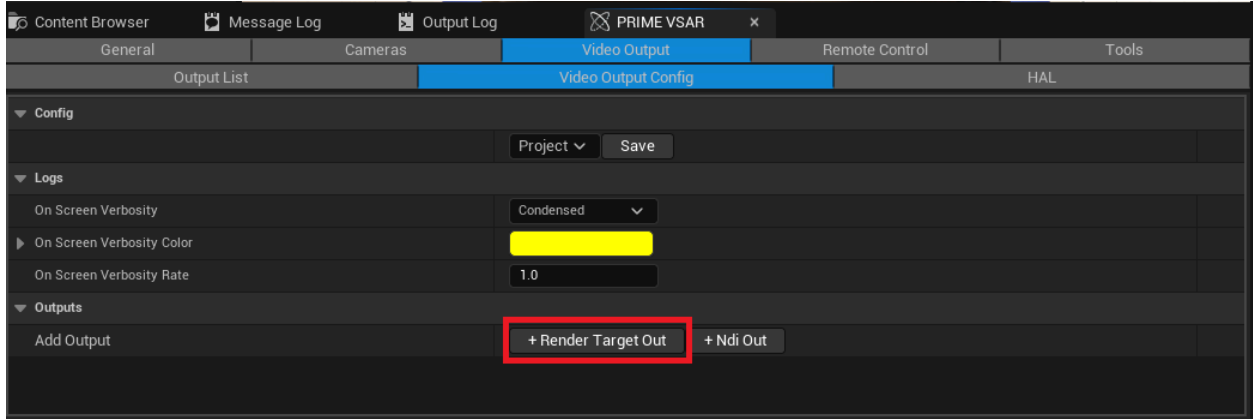

Set the Render Target input to the before created Render target

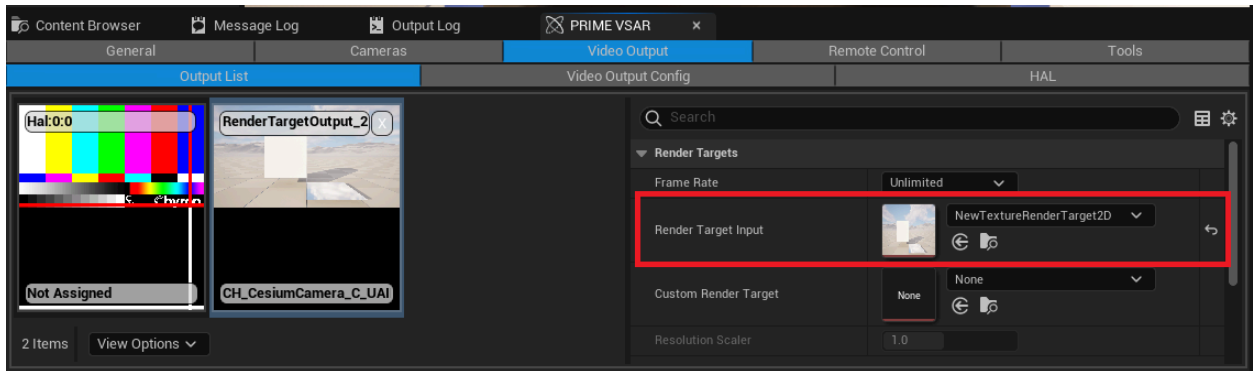

In the corresponding Cesium Camera in details panel select in the Video Output -> RenderTargetOutput

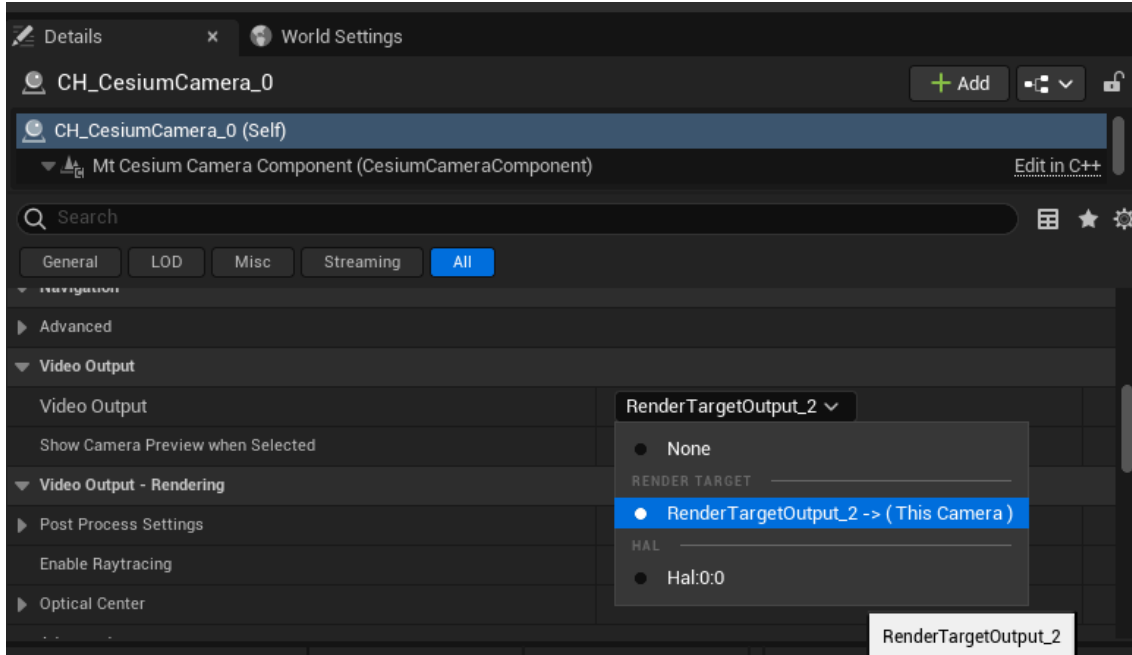

Make sure that the deferred capture is enabled under Video Output - Rendering -> Advanced -> Use Deferred Capture

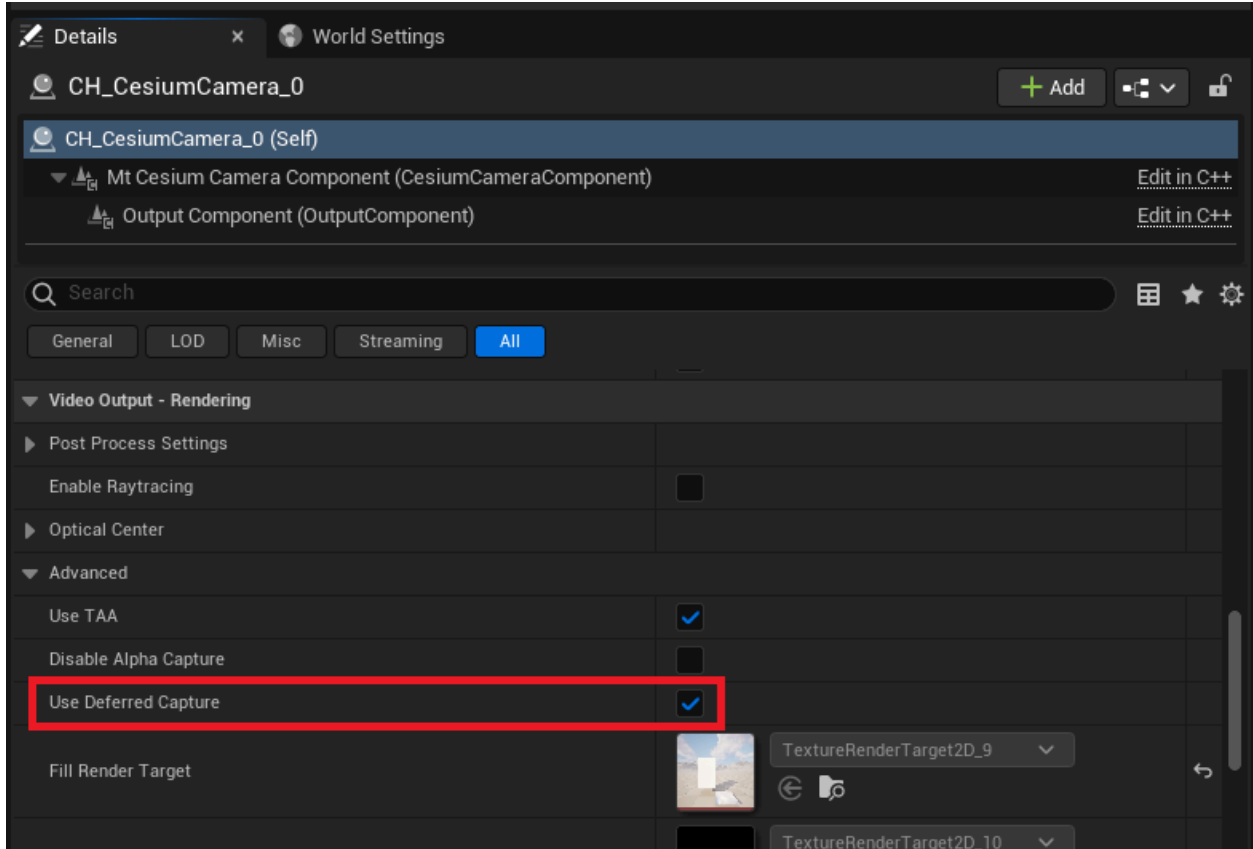

Make sure to save the output configuration

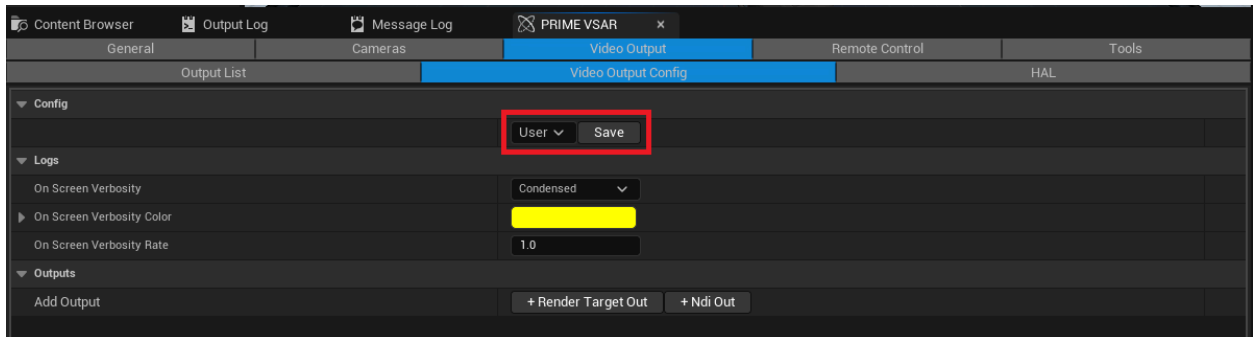

Make sure to Save all

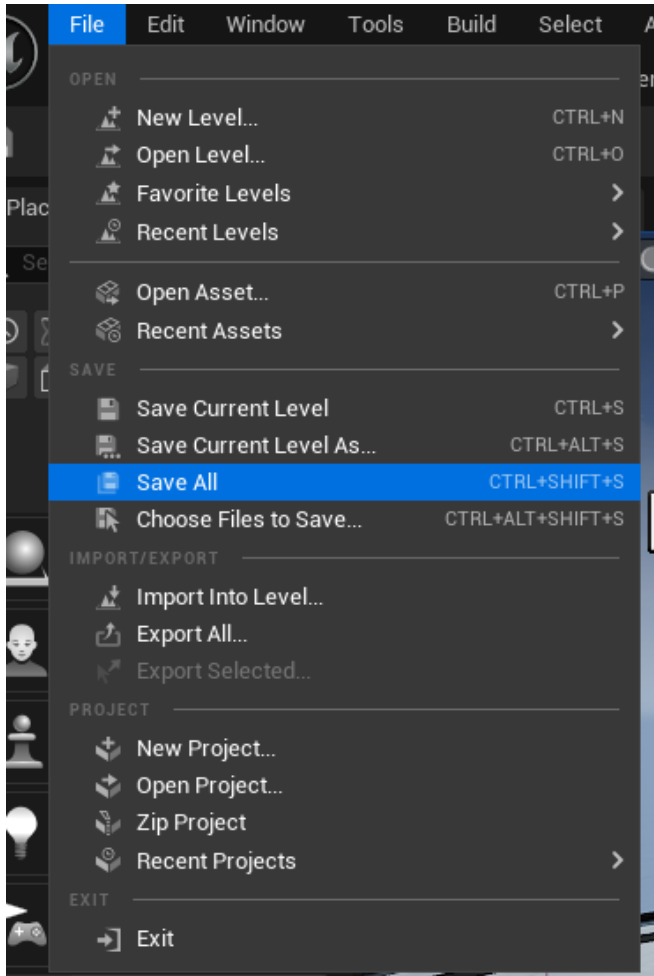

Launching nDisplay

While launching nDisplay it launches a standalone application that may take some time to boot up and will appear black while it is loading.

There are two main ways to launch nDisplay configuration:

using Launch nDisplay

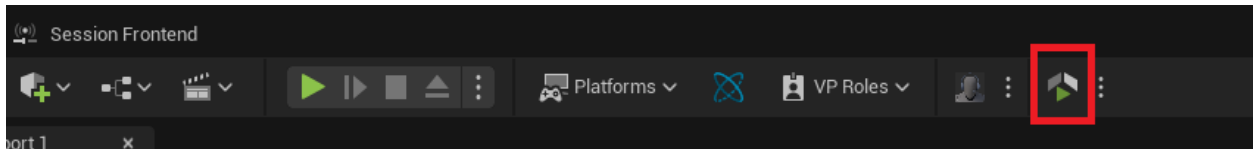

It requires nDisplay config to be in the scene. When using Launch nDisplay the Editor can consume SDI inputs/outputs due to the Editor and standalone application having the same settings.

using Switchboard

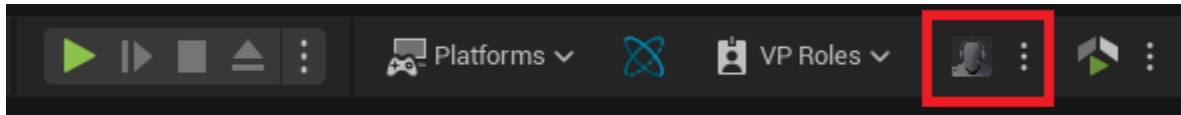

First launch of the switchboard requires installation.

Select .uproject file for project if not populated automatically

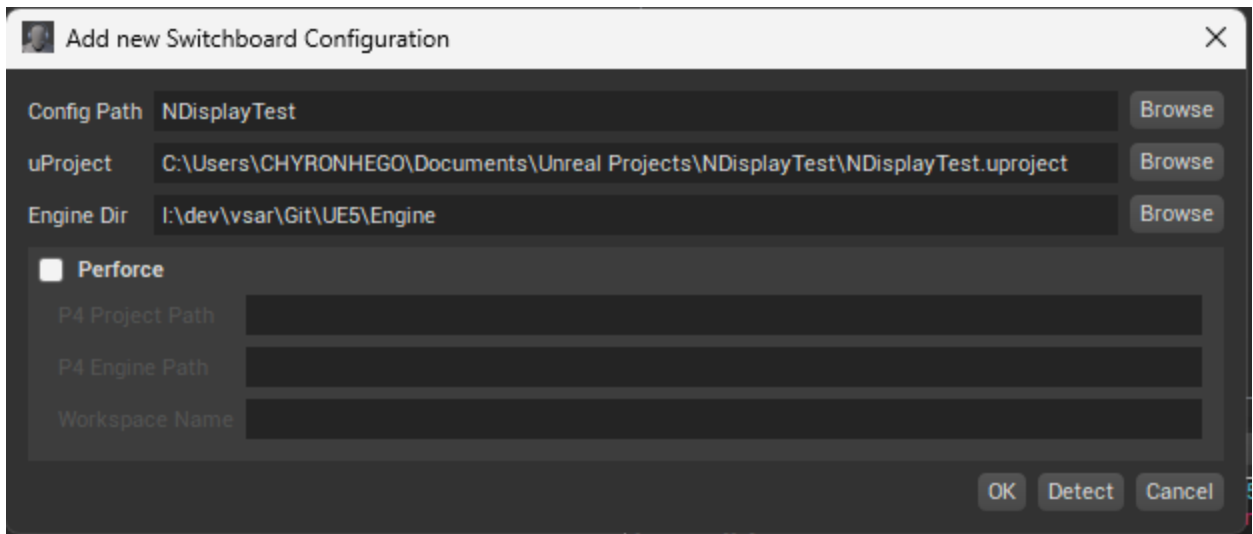

select correct level

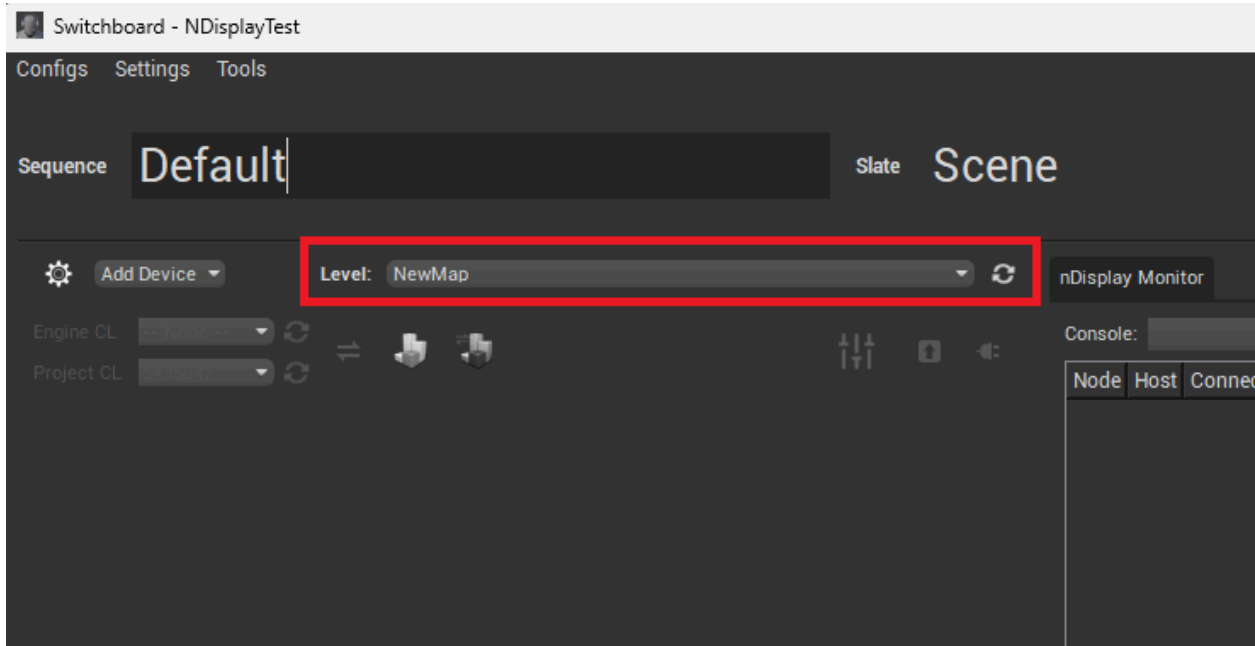

Add Device nDisplay one for each

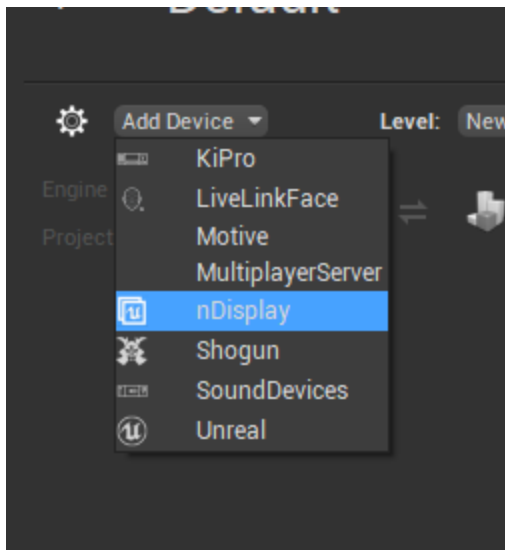

Select nDisplay Config file

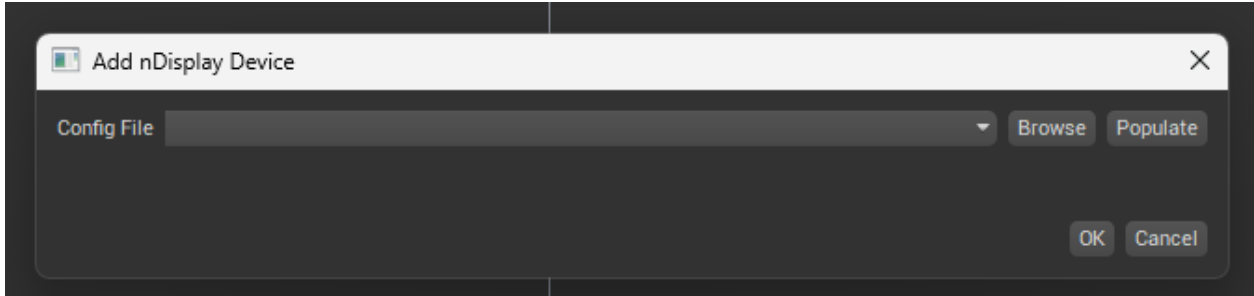

Launch the switchboard listener on all VSAR machines you want the nDisplay config to run on

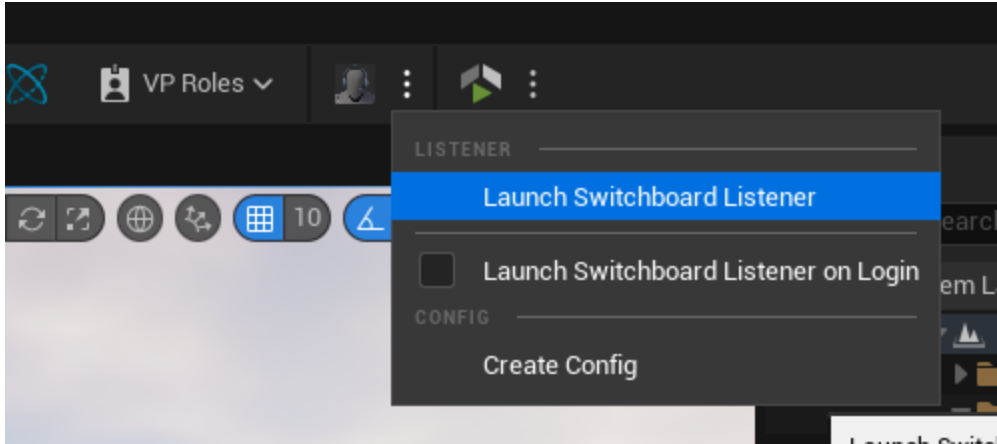

Close VSAR on all VSAR machines you want the nDisplay config to run on

Click the connect button to try to connect to all the nodes

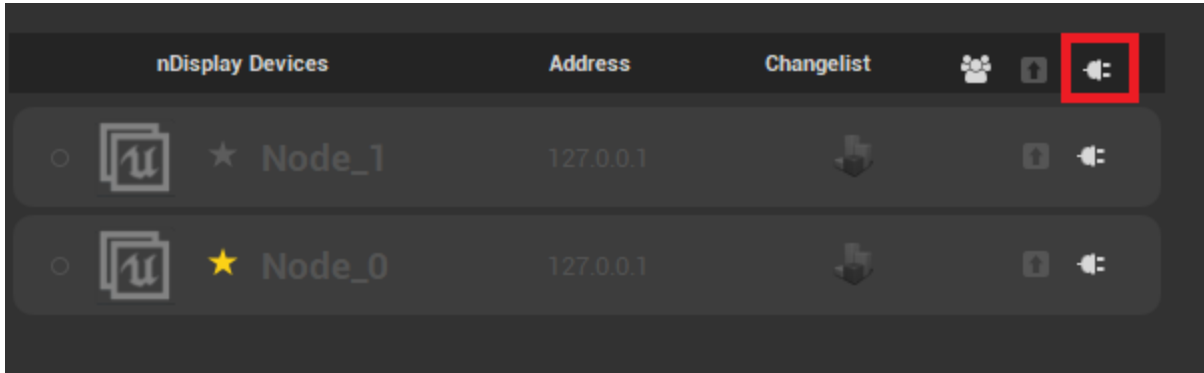

you can start all nodes using the start button (up arrow)

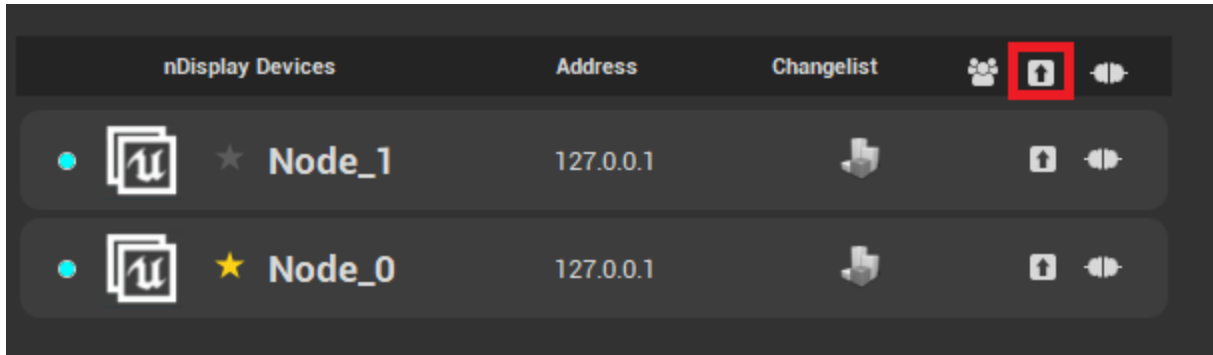

you can rebuild the node to update it to the project changes, unfortunately this requires development environment

PRIME VSAR OVERVIEW

PRIME VSAR is a plugin for Unreal Engine 5 and is developed as such. That being said, it installs its own modified version of Unreal Editor.

PRIME VSAR brings the following elements to UE5:

- Video I/O.
- Interface with tracking (Cesium).
- Primitives (a set of procedural geometries, for instance to address some business graphic purposes).
- Interface with CAMIO Universe.
- A/B Switch (a tool to manage transitions between media, comparable to a small video mixer/switcher).
- Exposes UE5 and PRIME VSAR core elements to LUA scripting.
- A subset of related functions/materials/components.

Most of these elements can be managed via the Configuration Panel.

Creating a PRIME VSAR Project

VSAR Full Build

- 1) Start PRIME VSAR (Warning: this may take time to load, especially during the first start, (due to the shader compilation) see remark below.
- 2) Search for “PRIME VSAR”
- 3) Create a new or open an existing project.

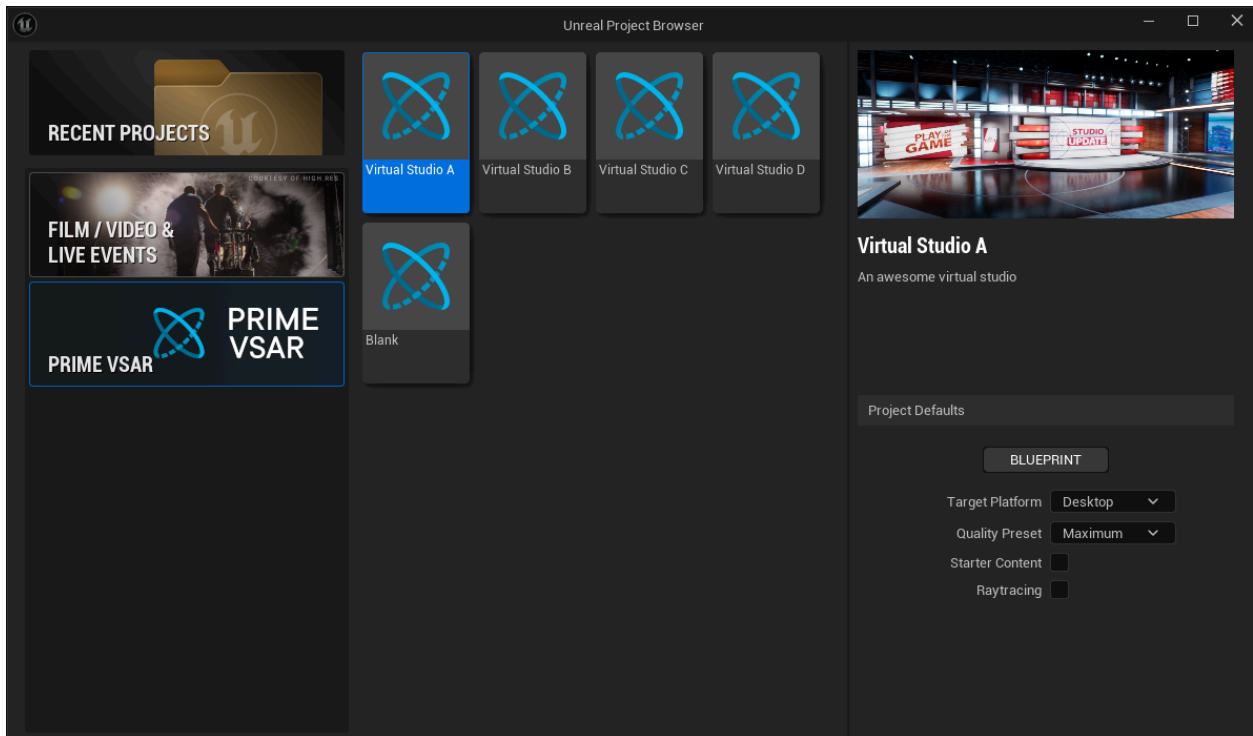

VSAR Plugin

- 1) Start Epic's Unreal Engine (Warning: this may take time to load, especially during the first start, (due to the shader compilation) see remark below.
- 2) Search for "PRIME VSAR"
- 3) Create a new or open an existing project.

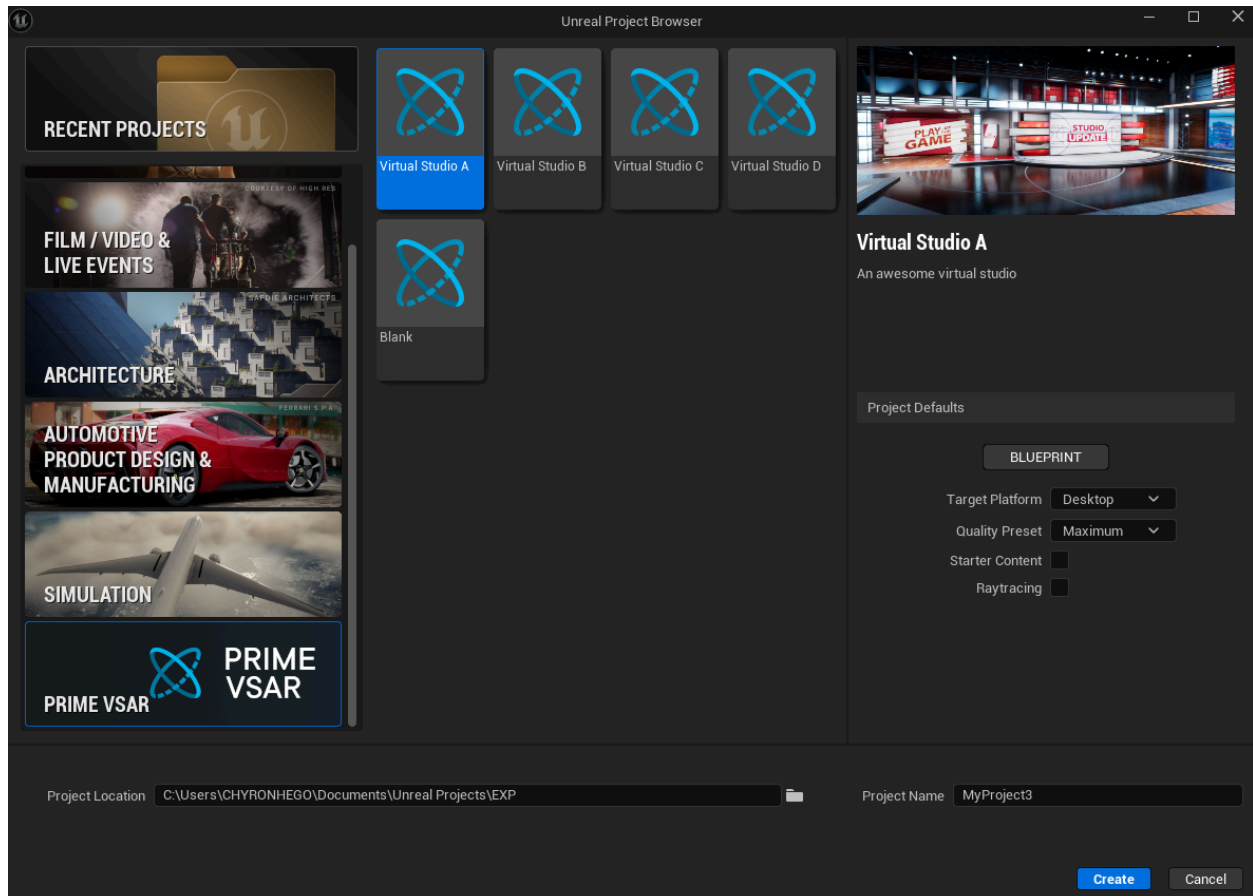

Select PRIME VSAR Example Projects by clicking on it to have it highlighted and enable the Next button.

PRIME VSAR comes with a couple of Virtual Studio samples originating from Unreal marketplace.

As for any Unreal projects, settings may be set up before creating it, but may be later changed.

It is recommended to have Maximum Quality and Desktop/Console by default.

PRIME VSAR Configuration Panel

Open the PRIME VSAR Config Panel by clicking on the top ToolBar close to Settings.

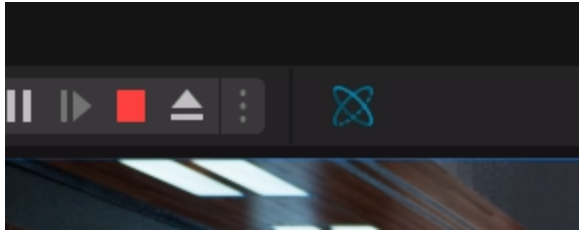

PRIME VSAR related info is located here.

The panel is divided into the following sections/tabs:

- **General**
- **Cameras**
- **Video Output**
- **Remote control**
- **Tools**

General

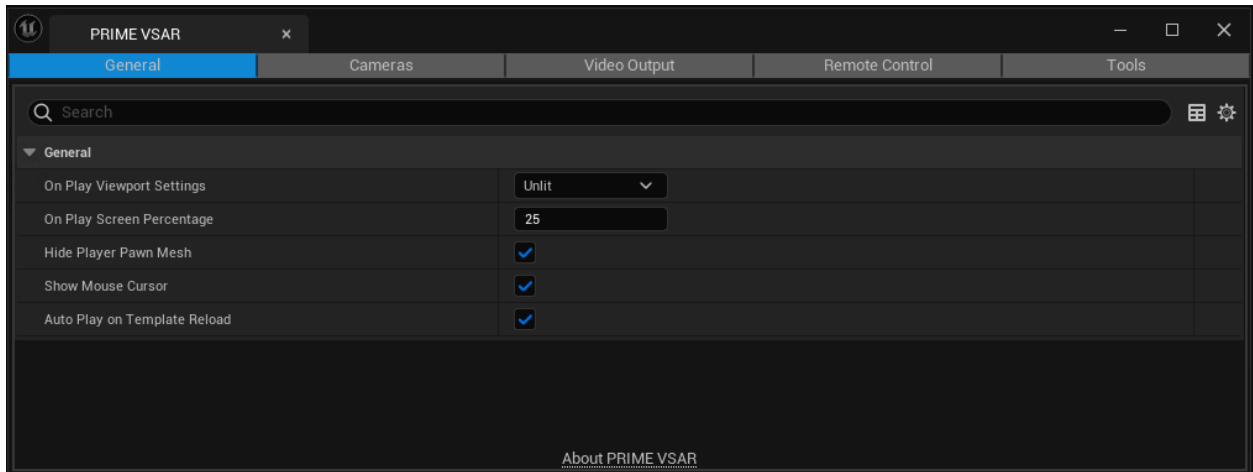

Options listed in this tab can be used while running in Play mode, mainly to decrease performance needs.

- On Play Viewport Settings:
 - Nothing: this settings leaves the quality of rendering on default presets.
 - Unlit: play with "Unlit" lightning mode - this decreases performance demands on the rendering
 - Disable Viewport: this completely disables viewport, which saves the most performance for the output rendering, Warning: Screen space reflections do not update and GPU Particles don't work when the viewport is disabled. There is large memory allocation over time that will require VSAR restart.
- On Play Screen Percentage:
Reduces rendering of the viewport resolution by percentage
- Hide Player Pawn Mesh:
(Checkbox checked by default) In Unreal, a default Player Pawn is created at play time as a sphere. Irrelevant for PRIME VSAR usage



- **Show Mouse Cursor:**

(Checkbox checked by default) Shows (or not) the cursor in the viewport while in play mode.

The *About PRIME VSAR* link at the bottom of the window will display the about dialog, showing current **PRIME VSAR** release info. Pressing any tab will switch back to its related content.

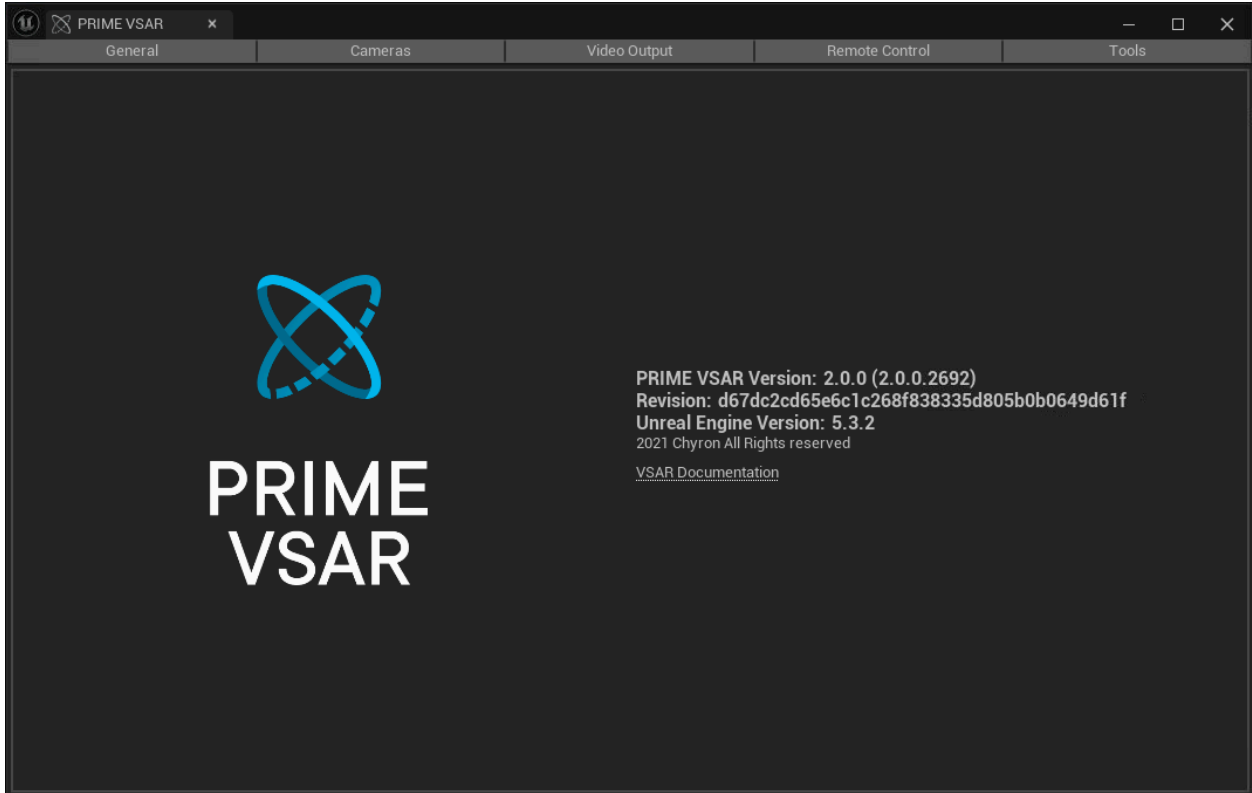

Cameras

For managing PRIME VSAR cameras.

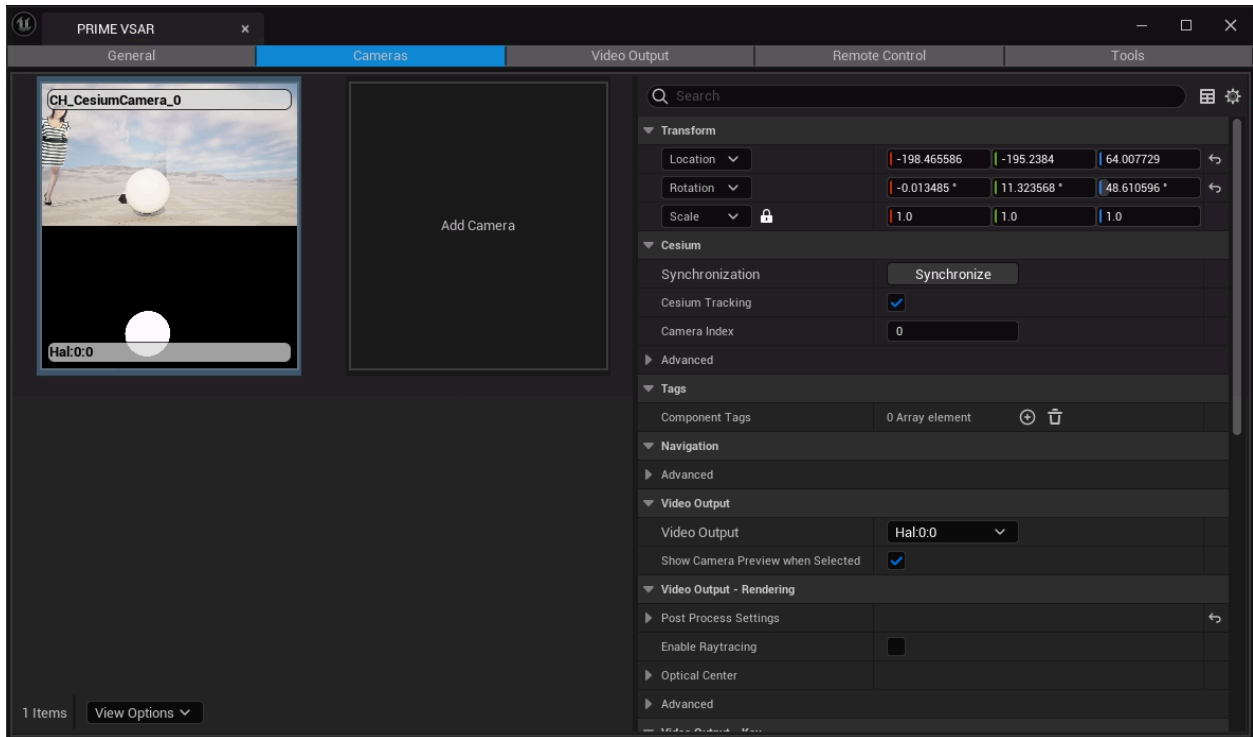

A PRIME VSAR camera, by default named CH_CesiumCamera (at first glance and for almost all applications) have 2 purposes:

- Generate an output onto Matrox playout ports through HAL or through NDI (Not supported in 2.0.0 release)
- Manage the communication with Cesium and thus the tracking data

In the above image, there is 1 available camera.

To create a new one, click the Add Camera button.

⚠ Maximum number of Cesium Cameras is 12

To set/get (and reveal) the video parameters of the camera, just select (click on) it.

Note: after upgrading the PRIME VSAR version, in some cases, opening an older PRIME VSAR .uproject with a previously created PRIME VSAR camera may show inconsistencies. It may be useful to delete and recreate it.

The right side of the panel shows (a subset of) the Details panel of the selected camera, also available in Unreal's standard Details one.

Transform

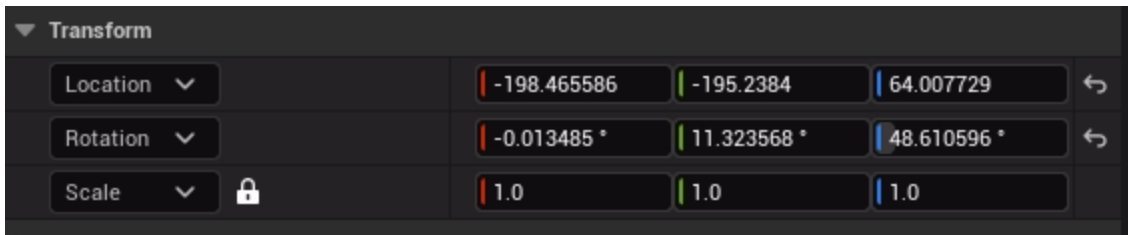

This shows the coordinates of the PRIME VSAR camera in space as for any UE Actor.

If Cesium is Activated (see below) these values come straight from Cesium data, and thus cannot be edited.

Cesium

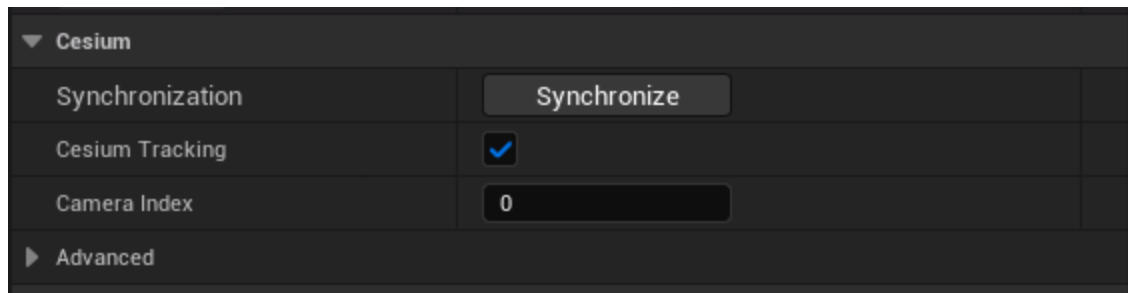

Synchronization

The Synchronize button allows for forcing immediate re-synchronisation with incoming Cesium data. Useful if you notice some introduced delay between real and virtual.

⚠ Unexpected delay may happen after dropping frames, and/or if you do some editing manipulations inside the Editor.

Cesium Activated

If unchecked this camera won't follow Cesium information. Should be checked for normal operation (camera tracking scenario).

Camera Index

Cesium software can handle multiple cameras. This figure selects which camera we want to use. Index starts at 0. This number relates to the Rig in Cesium (for example if we have two rigs in Cesium and we want to use the second one we would input 1 here)

Advanced Display (rev arrow ▼)

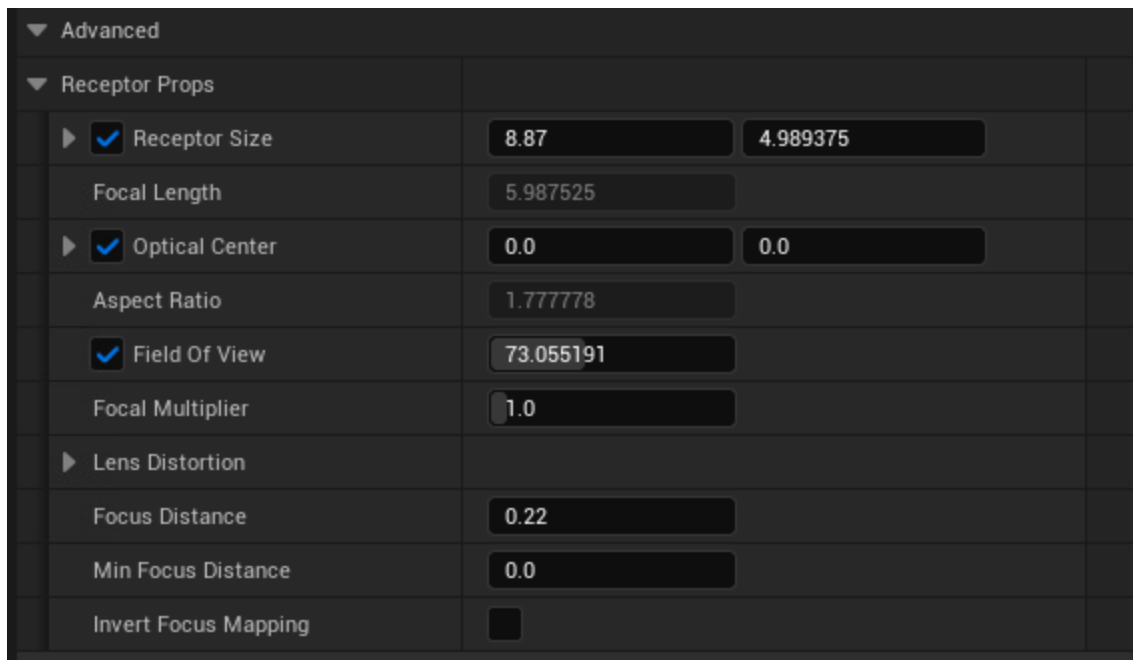

▼ Advanced	
▼ Receptor Props	
▶ <input checked="" type="checkbox"/> Receptor Size	8.87 4.989375
Focal Length	5.987525
▶ <input checked="" type="checkbox"/> Optical Center	0.0 0.0
Aspect Ratio	1.777778
<input checked="" type="checkbox"/> Field Of View	73.055191
Focal Multiplier	1.0
▶ Lens Distortion	
Focus Distance	0.22
Min Focus Distance	0.0
Invert Focus Mapping	<input type="checkbox"/>

These values display the current value of the cesium Camera. This feature can be used to check that you actually receive data from Cesium. If you move the camera these values should change (this can be verified eg. by using simulation drivers in Cesium).

Lens File

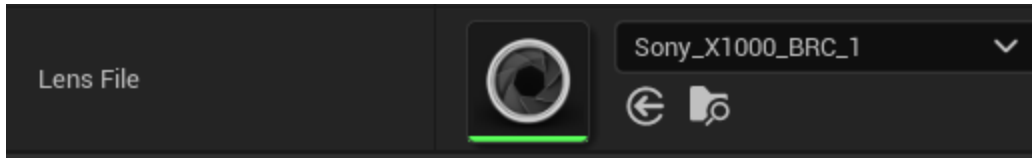

Cesium Camera allows loading Unreal Engine lens files (.ulens) as lens distortion files. When Cesium Camera works with a .ulens file within VSAR, the lens file value in the Cesium software must be set to "Unreal Lens File."

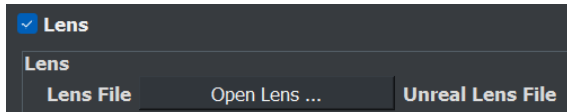

This way, Cesium delegates the lens distortion information to the local VSAR file. For more information check Cesium Reference Guide.

Video Output

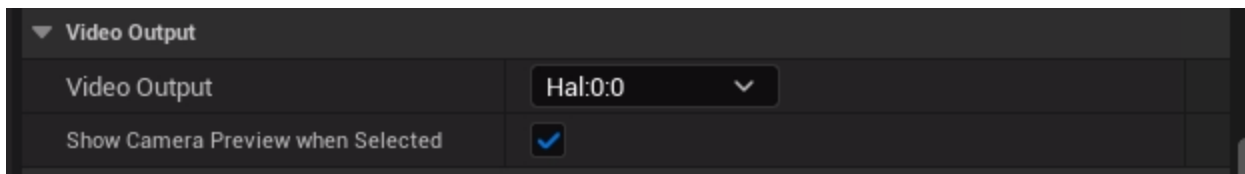

To select which available output will be used for this camera.

The dropdown list is contextual to what outputs are available in the session.

See below regarding the Video Output tab.

Defaults to Hal:0:0 (for a standard workstation with one Matrox board installed).

Video Output - Rendering

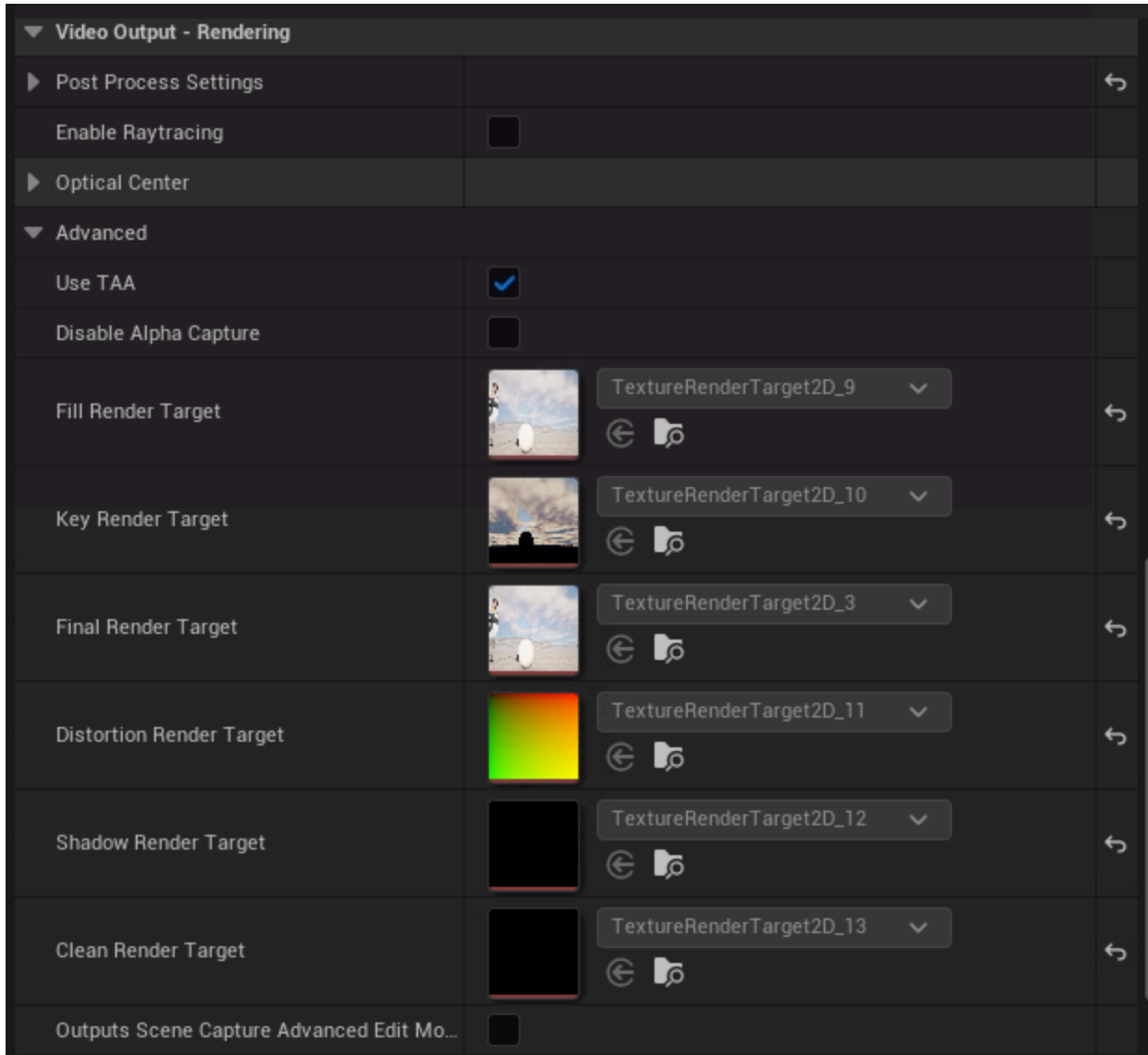

Post Process Settings

A list of Unreal camera's rendering parameters.

Optical Center

When it comes to calibration/registration/targeting of the real camera, you need to check the optical center and target positions. Optical center display parameters are set here:

- **Optical Center Show**

Displays or not the optical center. During normal operations it should be unchecked.

- **Optical Center Color**

Color of the center lines

- **Optical Center Thickness**

Thickness of the center lines

Note: this displays a cross on the whole screen, both in RGB and Alpha channels, so that it's always in front of everything when using any keyer with external matte feature.

Advanced settings (revealed when clicking on the down arrow ↓).

Use TAA

Checked by default. For using Temporal Anti-Aliasing on the output. This setting smooths out jagged edges of objects in the scene.

⚠ For this to work TAA needs to be also selected in the project setting as the Anti-Aliasing mode.

Disable Alpha Capture

To disable management of alpha channels.

Could help increase performances if no alpha is needed. (for most use-cases by very little)

Enable Distortion

To be checked when Cesium data is providing lens distortion info.

Then a list of Unreal Render Targets is used for generating the output.

Each of them may be visualized in Unreal's texture editor by double clicking on it.

Fill Render Target

RGB components for the rendered video output.

Key Render Target

Alpha components for the rendered video output.

Final Render Target

Combination of both above.

Distortion Render Target

The texture used for rendering distortions.

Shadow Render Target

The texture used to render shadows and reflections in Augmented Reality mode.

Outputs Scene Capture Advanced Edit Mode

Enabling this will display the Fill_SceneCaptureComponent and Key_SceneCaptureComponent allowing you to edit more advanced parameters.

Video Output - Key

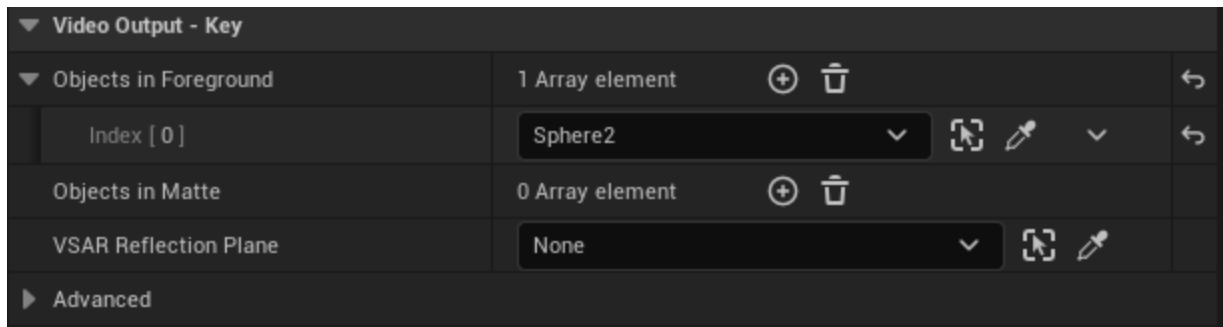

Objects in Foreground

Set the list of Actors that are going to be displayed in the Fill and Key signals. Usually used to have objects in front of the talent.

Should usually be used for the Targets (see **below**).

Objects in Matte

Set the list of Actors that are going to be displayed in Key signal only. Usually used to hide parts of the real sets (ceilings, walls,...)

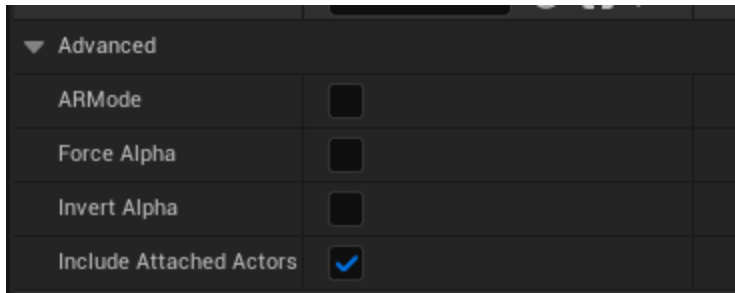

Advanced settings (revealed when clicking on the down arrow ↓).

Force Alpha

Forces a full white alpha output.

Invert Alpha

Inverts the alpha.

AR mode

Hides objects in fill that are not in the foreground.

AR mode Background

Select a texture as a background signal for AR, usually the video signal from the tracked camera. If the AR texture is cleaned up, AR objects are rendered without a background.

Include Attached Actors

Applies to the actors in the Foreground/Matte lists and also all of their children.

Matte Plane

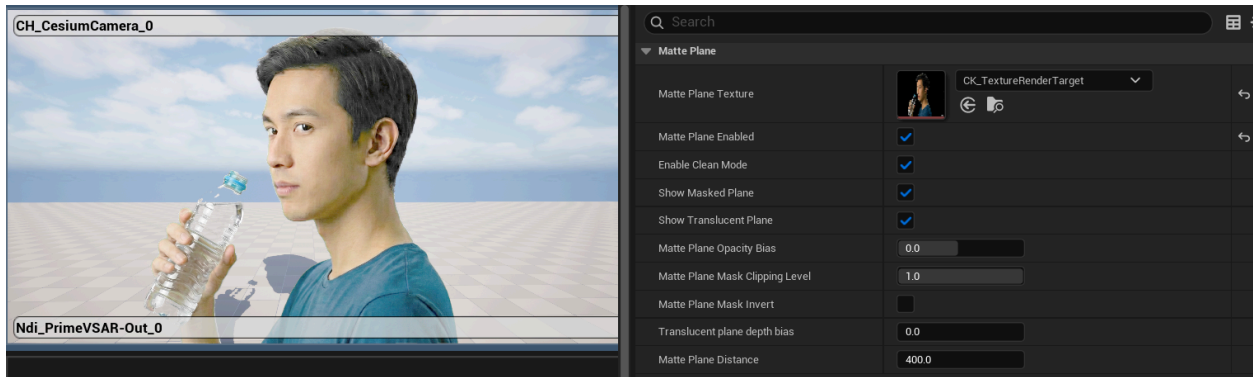

The Matte Plane is a surface always facing the camera, and exactly fulfilling the PRIME VSAR camera field of view. If the camera moves or rotates it will follow it (it is attached to the camera).

Its purpose is to immerse the Video In (talent) into the 3D world, in front or behind other compositions

Matte Plane Texture

The texture applied on the object. Usually using the Video Input as a media source.

Matte Plane Enabled

To use it (or not).

Enable Clean Mode

Clean Mode allows to capture the Talent's video feed cleanly, without applying any texture filters or tonemapping. Clean Mode only works with Masked materials, as it uses Custom Depth Stencil.



Original



Without Clean Mode Enabled



With Clean Mode Enabled

By default, all VSAR templates are compatible with the Clean Mode. However, if you want to use this feature in your own project, here's how to activate it:

1. Go to Edit
2. Open "Project Settings"
3. Type "custom depth" on the top search bar
4. Under Postprocessing > Custom Depth Stencil Pass select "Enabled with Stencil"

Additional Clean Mode options

Clean Mode consists of two modes that can be combined or used separately. Masked mode works on a material with the Blend Mode set to Masked, while Translucent mode works on a material with the Blend Mode set to Translucent. By default, both are combined to achieve accuracy in RGB and Alpha pixels.

- *Show Masked Plane* - Enable/Disable Mask mode
- *Show Translucent Plane* - Enable/Disable Translucent mode

Matte Plane Opacity Bias

Additional control over the opacity of the Alpha channel of the Matte Plane texture (0 -> 1).

Matte Plane Mask Clipping Level

Additional control over the clipping of the Alpha channel of the Matte Plane texture (1 -> 0).

Matte Plane Mask Invert

Inverts Alpha channel of the Matte Plane texture.

Translucent Plane depth bias

This control allows to override the intersection between the Matte Plane and the floor, so that the plane can be positioned in front of the floor, to align virtual shadows and reflections with the talent's video signal.



Without Depth Bias

With Depth Bias

.Matte Plane Distance

Distance of the object to the camera in UE units (centimeters).

 Size is aligned to the camera projection making it look like nothing changed when adjusting Plane Distance.

Matte Plane Advanced Component Edit Mode

When checked, UE's Details panel shows up all the parameters of the PRIME VSAR camera, otherwise, only a subset is displayed.

Matte Plane Scale Offset

Adds a scale bias to the Plane. The default value is 1 and makes the plane exactly fill the camera viewport.

Matte Plane Location Offset

Adds a translation bias to the Plane. The default value is 0. and makes the plane exactly fill the camera viewport.

Matte Plane Rotation Offset 1

Adds a rotation bias to the Plane, prior to the translation. The default value is 0. and makes the plane exactly fill the camera viewport.

Matte Plane Rotation Offset 2

Adds a rotation bias to the Plane, after the translation. The default value is 0. and makes the plane exactly fill the camera viewport.

Compensate Optical Center

Apply or do not apply the Cesium optical center to the plane.

Video Output

For managing all possible Outputs:

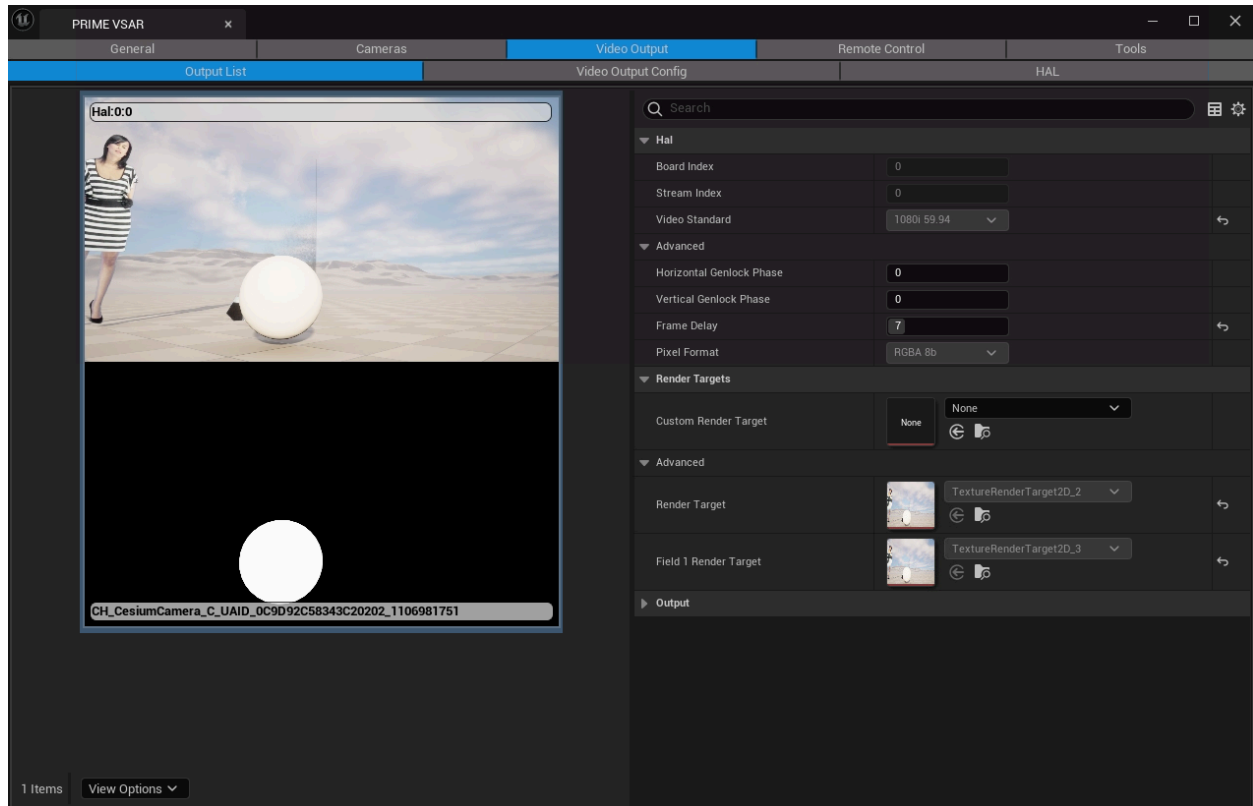

This Tab displays the following sub-tabs:

- Outputs
- Video Output Configuration
- HAL

Outputs

This tab details the parameters related to the video outputs available for any CH_CesiumCamera (see above).

Each extra output (NDI) may be easily deleted using the “X” button on the top right corner.

⚠ (NDI is Not supported in 2.0.0 release)

The right side panel displays the different parameters related to the selected output, as Details does

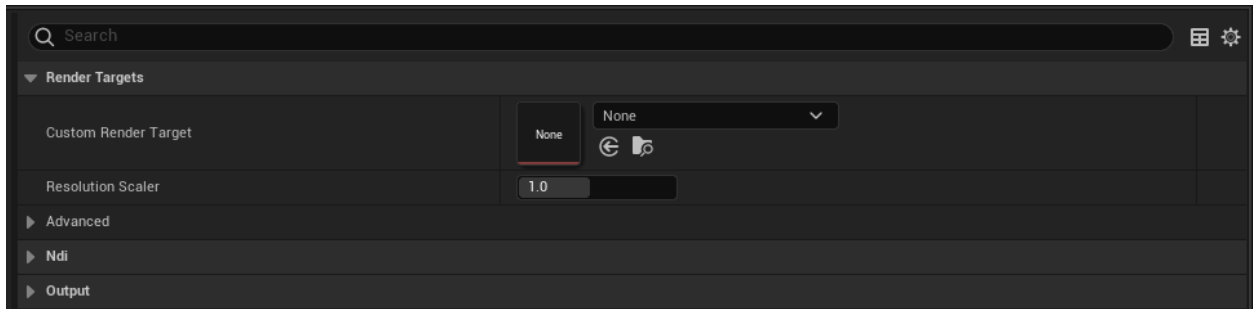

Custom Render Target

when inserted render target, this render target will be used as Output instead of the hardware.

Resolution Scaler

increases or decreases the rendered resolution then it gets covered to output resolution. For example, when we have 1080p resolution and we set this value to 2 we can use this as a custom super sampling anti aliasing, as it will render in 4k and then be scaled to 1080p.

⚠ for interlaced mode we recommend using only scale larger than 1.5 or TAA but not both at the same time.

Render Targets

Render Targets used for the selected video Output. Also called 'Render Texture' in the Game industry, it is used to make an intermediate calculation as a Texture or surface, e.g. to handle the Fill, the Key or any extra composition.

Output

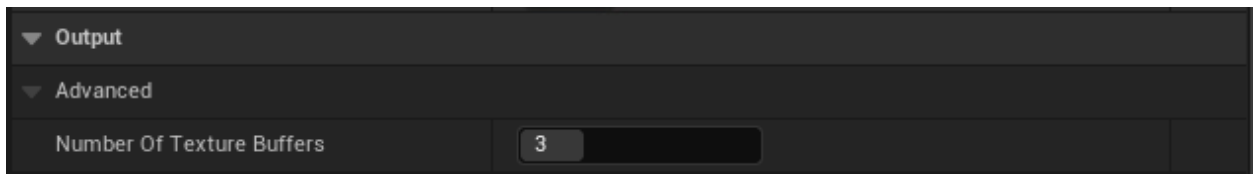

Number of Texture Buffers (from Unreal ToolTip)

Number of textures used to transfer the texture from the GPU to the system memory.

A smaller number is most likely to block the GPU (wait for the transfer to complete).

A bigger number is most likely to increase latency.

Video Output Configuration

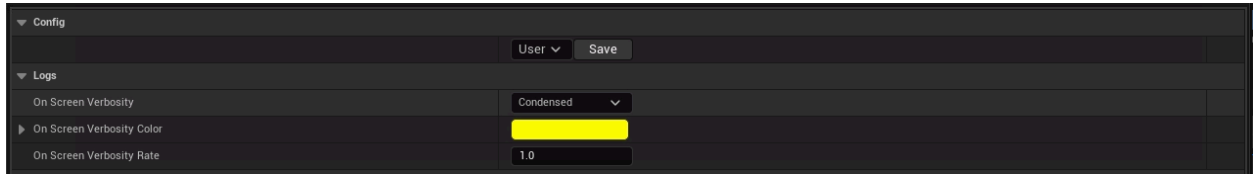

Mostly used for eventually generating new NDI outputs (via the “+ NDI Out” button).

⚠️ (NDI is Not supported in 2.0.0 release)

Config

Advanced: Entry for managing the video configuration file. Configuration files may be User or Project-wise. This file should not be confused with Hal.xml, which is the HAL configuration file.

Default is User-mode.

The user file is %LOCALAPPDATA%/ChyronHego/Fresh/VideoOutputConfig.json\

The project file is displayed, as a tooltip, when you hover the mouse on top of the drop down box.

Logs

Entry for managing On Screen Verbosity. Changes the level of detail of HUD messages in the editor window.

Helpful for monitoring and analyzing real-time efficiency.

When set to Condensed or Verbose, the viewer will display subsequent lines informing the state of the calculation, as long as Viewer’s parameters have Show Stats checked.

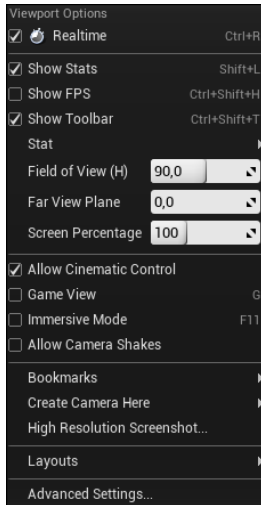

The time rate between each line is driven by the On Screen Verbosity Rate (in seconds).

For example in Condensed mode, you may read:

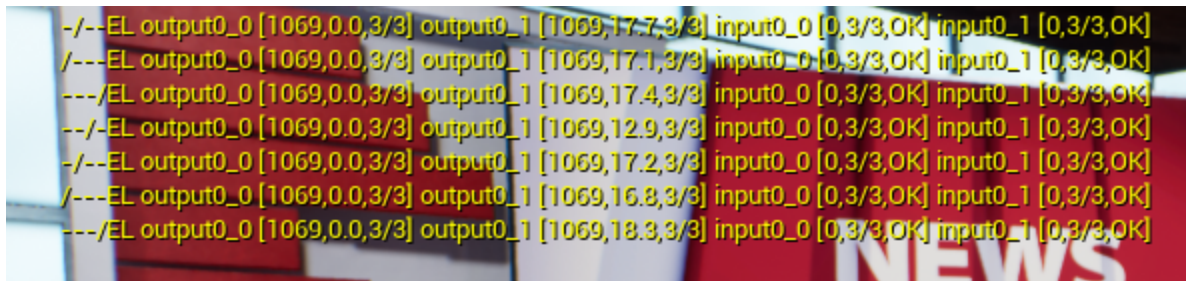

Meaning:

E : externally genlock required

L: genlock is locked.

output0_0: logs for the first output

1069: number of drop frames since PRIME VSAR started

0.0: idle time (milliseconds)

3/3: output fifo fill. In normal operation this should be N/N.

output0_1: logs for the second output

1069: number of drop frames since PRIME VSAR started

18.3: idle time (milliseconds). Means that there are 18.3 milliseconds left when rendering a frame. A frame usually last 40ms, or 33.6 ms. So 18.3 is a good score. Note that only the last output will contain the relevant idle time.

3/3: output fifo fill. In normal operation this should be N/N.

input0_0: logs for the first input

0: number of dropped frames since PRIME VSAR started

3/3: input fifo fill. In normal operation this should be 0|1/N. Having 3/3 means that the video is not currently used in the scene

OK: video is present on the incoming BNC.

input0_1: logs for the second input. Same fields as upper.

HAL

A read only entry displaying how HAL is configured. This configuration can be changed by editing the HAL.xml file and restarting PRIME VSAR.

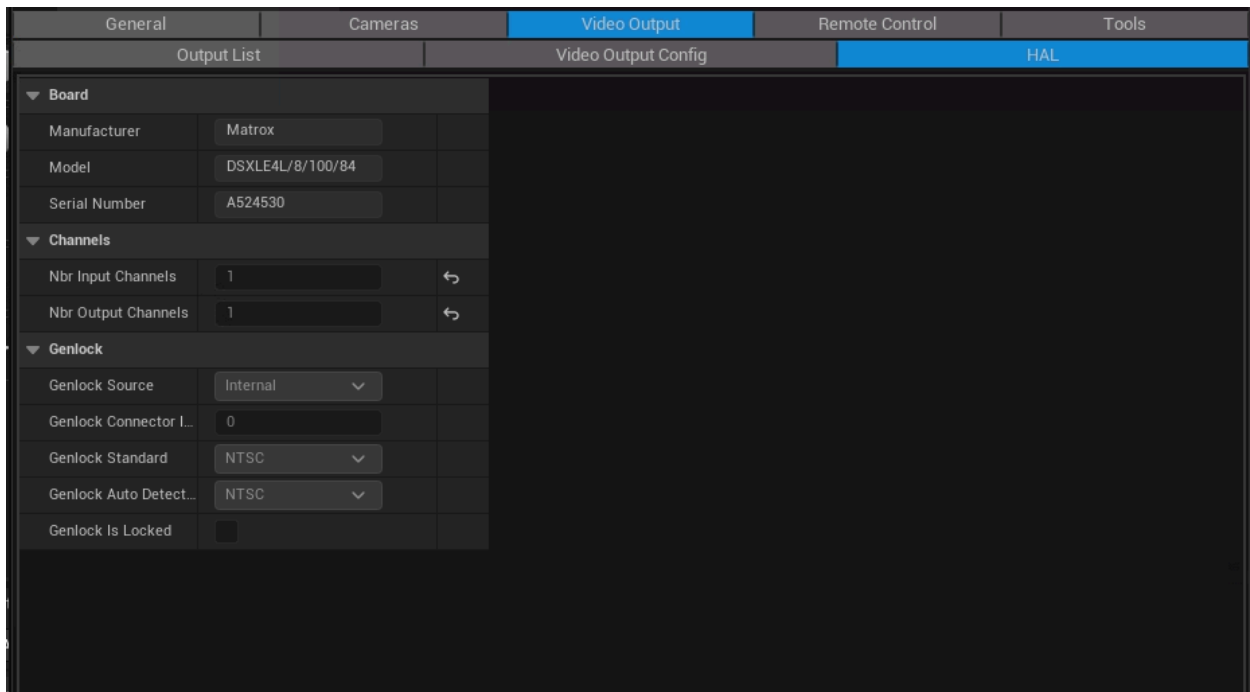

Remote Control

For managing communication with external utilities, mainly Cesium (tracking), DataEngine (CAMIO and remote Lua triggering) and Lua scripting.

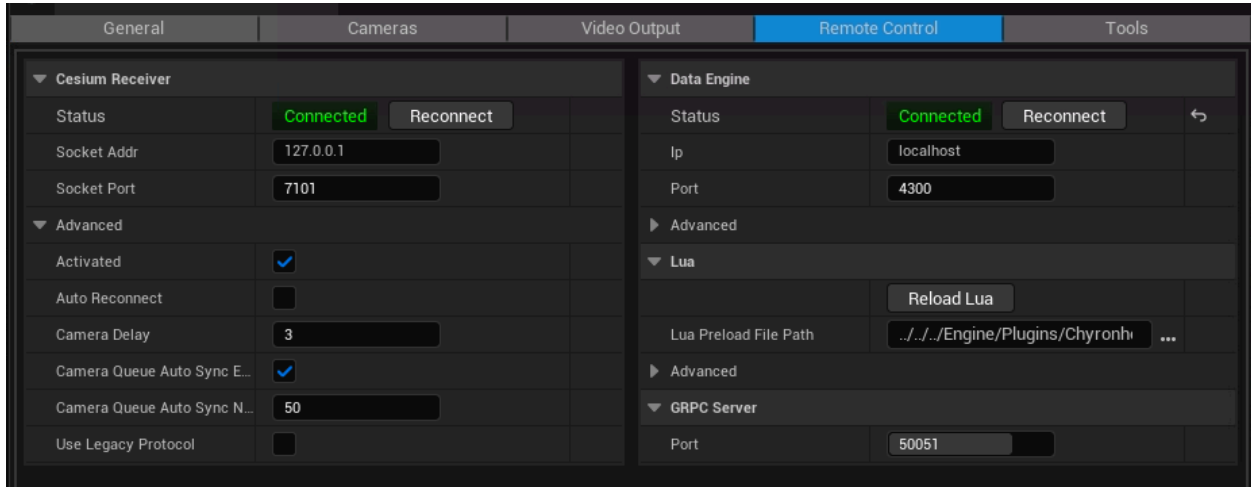

Cesium Receiver

Status

Connected is displayed in Green when the communication occurs with Cesium (this does not necessarily mean that PRIME VSAR is receiving proper data, see below Testing). A Red label is displayed if Cesium is not connected (running).

The Reconnect button helps forcing reconnection if need be (network interruption, ...)

Note: If Auto Reconnect is checked (see below), then reconnection will happen automatically.

Socket Addr

The name/ip of the machine where Cesium is running

Socket Port

The port onto which Cesium delivers data.

Defaults to 7100 for Legacy protocol. (in VSAR “Use Legacy Protocol” under VSAR Config -> Remote Control -> Cesium Receiver -> Advanced, we recommend to not have this checked and use the new protocol instead)

Defaults to 7101 for the new protocol.

Extra advanced Parameters (revealed when clicking on the down arrow ↓).

Default values should cover most of the usual cases:

Activated

Should be checked in normal operation. If unchecked, cesium camera data won't be read anymore. This can be useful for outputting video for non-cesium cameras.

Auto Reconnect

If checked, Cesium will automatically be reconnected when a disconnection happens. In normal operation, it should be checked.

Camera Delay

Queue is used to smooth out network data transmission. Incoming data from cesium is appended to the Queue(s) and then used by an individual camera on tick. If the rate of camera data is not genlocked to PRIME VSAR video frame rate, then at some moment a desynchronisation of the queue may happen. VSAR automatically tries to sync the Queue to be as close to the aimed Camera Delay while the camera is not moving.

- CameraDelay - how many frames of delay should be between Cesium and VSAR. This also determines the Queue size, which is CameraDelay times two plus one, In example of delay 3 the Queue size will be 7.
- CameraQueueAutoSyncEnabled - enables auto Synchronization functionality where the frame counter jumps in time to current Queue size - CameraQueueSyncOffset, after camera synchronization has happened camera may jump in space.
- CameraQueueAutoSyncNumPass - number of frames that are desynced before Synchronization is triggered (CameraQueueAutoSyncEnabled has to be enabled)

▼ Advanced	
Activated	<input checked="" type="checkbox"/>
Auto Reconnect	<input checked="" type="checkbox"/>
Camera Delay	3
Camera Queue Auto Sync Enabled	<input checked="" type="checkbox"/>
Camera Queue Auto Sync Num Pass	50
Use Legacy Protocol	<input type="checkbox"/>

Data Engine

Remote triggering is handled via CH Data Engine.

Data Engine remote control is mainly used by Chyron Panels (LAP) and CAMIO (among others).

Status

Connected is displayed in green when the connection with DE is alive. If it's not the case, click Reconnect.

Reconnect

Force the reconnection to the DataEngine.

IP

IP address of the machine where the DataEngine is running. 127.0.0.1 stands for localhost.

Port

Port used by the DataEngine (defaults is 4300)

Extra advanced Parameters (revealed when clicking on the down arrow ↓):

Auto Reconnect

When checked, as soon as the DataEngine disconnects, it will be automatically reconnected.

Reconnect Delay

Timeout in seconds, before the DataEngine is declared disconnected.

Lua

Lua Preload File

When PRIME VSAR is started, a Lua initialization is loaded. The default file is:
../../MtLuaPreload/Main.lua.

It will load several Lua libraries useful for VSAR. If you need to add your own Lua initialization scripts, most of the time, instead of changing the path of this file, it's better to edit this file and add your own file entries.

Clicking Reload Lua will execute the file content again.

Extra advanced Parameters (revealed when clicking on the down arrow ↓):

Bucket

The DataEngine bucket used to communicate with PRIME VSAR (Default: ue4).

Lua in Key

Bucket's key where PRIME VSAR should read the Lua commands to execute (Default: lua_in)

gRPC Port

sets port on what the gRPC Server is run on, this connection is important for VSAR Controller service.

Intelligent Interface

Intelligent Interface is remote control protocol. Works similar to Prime Intelligent Interface. VSAR receives messages on either UDP or TCP (specified by Protocol) on the specified Port. Received message is decoded by selected Encoding format and then matched against command patterns.

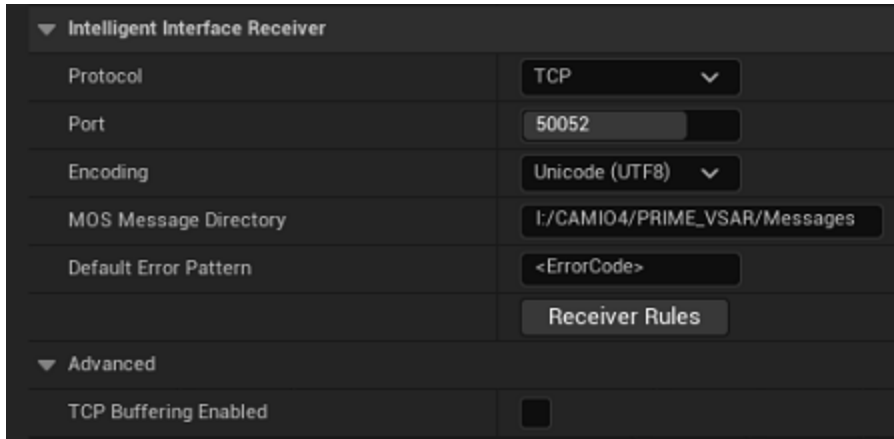

The screenshot shows the configuration interface for the Intelligent Interface Receiver. It is organized into two main sections: 'Intelligent Interface Receiver' and 'Advanced'. The 'Intelligent Interface Receiver' section includes the following settings:

- Protocol:** A dropdown menu set to 'TCP'.
- Port:** A text input field containing '50052'.
- Encoding:** A dropdown menu set to 'Unicode (UTF8)'.
- MOS Message Directory:** A text input field containing the path 'I:/CAMIO4/PRIME_VSAR/Messages'.
- Default Error Pattern:** A text input field containing '<ErrorCode>'.
- Receiver Rules:** A button to access the rules configuration.

The 'Advanced' section includes:

- TCP Buffering Enabled:** A checkbox that is currently unchecked.

MOS Message

Directory is path where should be MOS files located and in this directory will VSAR try to find MOS files in case, that message does not contain a full path to MOS but just its ID or basename. This property can be changed using blueprint node SetMOSMessageDirectory. When changed via blueprint, property editor in VSAR config will not be updated, but value will be changed. To see this change, close VSAR Config panel and open again. Default Error Pattern is used in case no rule will match incoming messages or selected commands in all matched rules are missing some arguments. All of those settings are project specific. During execution of some commands, the opened project can be switched. TCP Buffering Enabled checkbox is visible just if Protocol is selected as TCP. This option is overriding default behavior (handle each packet as a CII message), and is buffering (concatenating) the packets to one big message. Messages need to be delimited by CRLF.

By clicking on the Receiver Rules button, DataTable asset editor containing rules table is opened. Here, there are predefined rules with their patterns, and user can alter patterns, responses or behaviors.

Row Name	Command	Message Pattern	Success Pattern	Error Pattern
1 LegacyLoadMos	Legacy Load MOS	V\5\3\1\<MosObject>\	*	<ErrorCode>
2 LegacyLoadMosWithArguments	Legacy Load MOS With Replacables Values	V\5\3\1\<MosObject>\<OrderedReplaceablesValues>\	*	<ErrorCode>
3 LegacyTakeMos	Legacy Take MOS	V\6\<MosObject>\	*	<ErrorCode>
4 LegacyStopMos	Stop MOS	L\<MosObject>\animate\	*	<ErrorCode>
5 StopAll	Stop All	E\effectoutclear\<Channel>\	*	<ErrorCode>
6 LoadMos	Load MOS	P\LOAD\<MosObject>\<NameValuePairs>\	*	<ErrorCode>
7 StopMos	Stop MOS	P\CLEAR\<MosObject>\	*	<ErrorCode>
8 PlayMos	Play MOS	P\PLAY\<MosObject>\	*	<ErrorCode>
9 PlayMosWithArguments	Play MOS With Arguments	P\PLAY\<MosObject>\<NameValuePairs>\	*	<ErrorCode>
10 PlayActorFunction	Play Actor Function	P\PLAY\<Actor>\<FunctionName>\	*	<ErrorCode>
11 PlayActorFunctionWithArgument	Play Actor Function with Arguments	P\PLAY\<Actor>\<FunctionName>\<NameValuePairs>\	*	<ErrorCode>

Patterns:

Patterns like the Prime Intelligent Interface consist of literals and arguments. Backslash is reserved character for argument delimiting. Arguments are enclosed in <>. Argument names are limited to alphanumeric characters and underscore. Using _ instead of <ArgumentName> will discard argument value. (P\PLAY_ \<FunctionName>\ will discard the first argument and use the second argument as FunctionName) Everything else (outside arguments and discard character _) is considered a literal and will be matched case insensitive.

This means that for Pattern: "TEST::\abracadabra\<ArgOne>_" following messages would match:

```
TEST::\abracadabra\1\
teSt::\AbracadabrA\with space\5
test::\Abracadabra\with:comma\5
test::\Abracadabra\with_underscore\5
```

For pattern: "SHOW\<key>:<val>\"

show\aaa:bbb\ (key will be "aaa" and val will be "bbb")

Special arguments:

- <OrderedReplaceablesValues> = backslash delimited arguments
- <NameValuePairs> = \name1\value1\name2\value2\
- <Values> = \name1:value1\name2:value2\

Special Arguments for reply pattern:

- <Command> = whole received message
- <ErrorCode> = 4 digit hexadecimal error code (just in Error Reply)
- <ErrorMsg> = Verbose error message (just in Error Reply)

Command	Needed Arguments	Behaviour
Legacy Load MOS	MosObject	Loads MOS object, replace replaceables, call Cue
Legacy Load MOS With Replaceables Values	MosObject, OrderedReplaceablesValues	Loads MOS object, replace replaceables (values from OrderedReplaceablesValues override MOS values, order is determined by MOS file), call Cue
Legacy Take MOS	MosObject	Loads MOS object, call Take (no replaceable is affected)
Stop MOS	MosObject	Loads MOS, call Stop
Stop All		Iterate trough all CamioTemplates and call Stop on each
Load MOS	MosObject, NameValuePairs	Loads MOS object, replace replaceables (values from NameValuePairs override MOS values, values are replaced by name of pair - order is not important), call Cue
Play MOS	MosObject	Loads MOS object, replace replaceables, call Take
Play MOS With Arguments	MosObject, NameValuePairs	Loads MOS object, replace replaceables (values from NameValuePairs override MOS values, values are replaced by name of pair - order is not important), call Take
PlayActorFunction	Actor, FunctionName	Find actors by name, if not able, find actors by label (regular expression matching), call function / invoke event
Play Actor Function with Arguments	Actor, FunctionName, NameValuePairs	Find actors by name, if not able, find actors by label (regular expression matching), call function / invoke event

Error Codes:

40B3	The requested asset could not be found
4190	The command is invalid
4191	The command is malformed
4192	An unknown error has occurred

Tools

A tab for managing specific dedicated tools like the Targets and ABSwitch features.

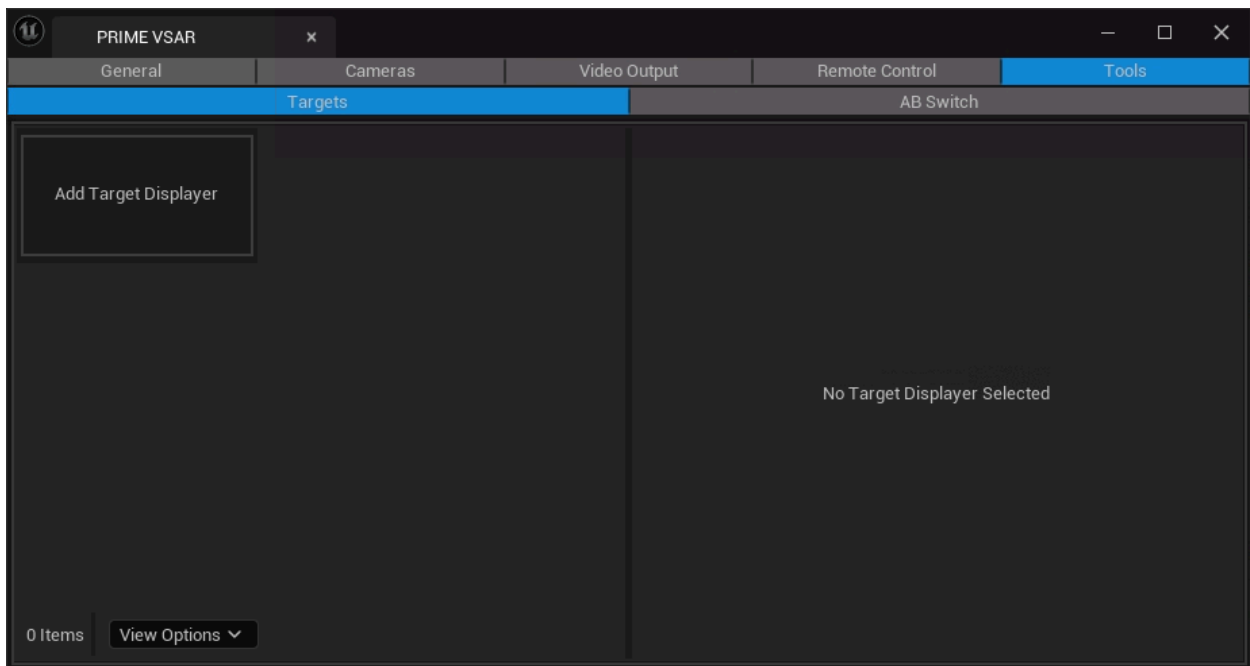

Targets

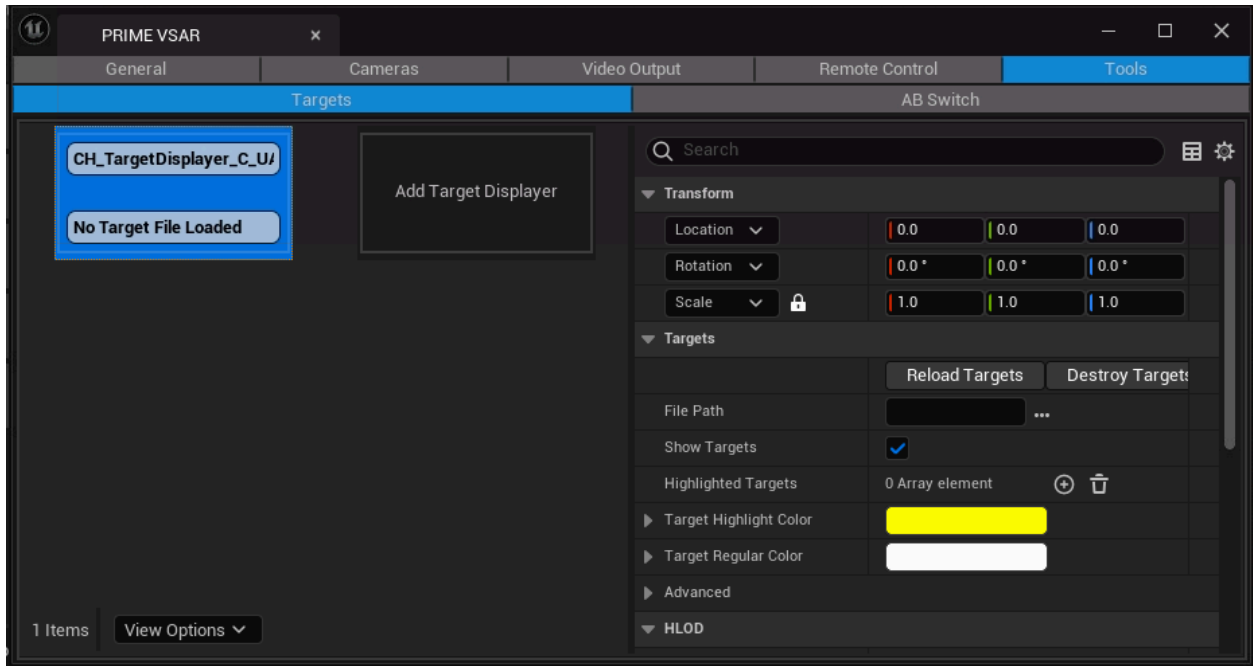

Used in Tracking mode, Targets are geometrical references (“dummies”) that should reflect physical (XYZ) real positions in your studio. They’re parented to a specific actor usually named CH_TargetDisplayer.

Their main purpose is to have in the 3D (virtual) environment references to the real world, either for calibrating/calibration checking or virtual object positioning.



If there are no Target Display objects created yet, click Add Target Display to create a new one.

Then, load the .tgt file by either entering the file path or clicking the “...” button, and press Reload Targets.

As for Cameras and Video Output tabs, the right side of the panel shows the Details of the selected element.

Transform: allows to globally translate, rotate, scale the targets. Note that in normal operation (ie to have a perfect match between Cesium and PRIME VSAR), the Transform should be set to Identity; that is: “Location=0,0,0”, “Rotation=0,0,0”, “Scale=1,1,1”.

Reload Targets: deletes and reload the targets based on the specified File Path.

Destroy Targets deletes all the targets contained in this target displayer object.

File Path: specifies the path to the target file (.tgt) to display. Usually, this file is the same as the one used in Cesium.

Show Targets: if unchecked the targets won't be displayed in the scene. In production, it should be unchecked.

Adding targets to Highlighted Targets will enhance display of the selected targets. You can control their color with Target Highlight Color, and control the color of other targets with Target Regular Color.

It is a good practice to have the targets displayed in foreground (see **Video Output - Key** above).

AB Switch

AB Switch is a tool to feature texture transitions mapped on a 3D object (for instance a virtual screen in your scenes where we expect transitions to happen).

It should behave close to standard A/B (or Program/Preview) transition effects in a mixer.

TESTING

Test Prime VSAR / Cesium connection

- 1) Get in the Config Panel, Cesium and check that Cesium is Connected in green.
- 2) Check that Activated is checked.
- 3) Check that the corresponding Cesium Camera has:
 - a) Cesium Activated checked.
 - b) Correct Cesium Camera Index (usually 0).
- 4) Do a zoom movement and check that the Field of View is moving accordingly.
- 5) Select the camera in the “World Outliner”, get in the Details panel and check that camera position and orientation are changing while you are moving the real camera.

Deeper testing can include:

- 1) IP/port configuration of Cesium and PRIME VSAR.
- 2) Check that Cesium camera in Cesium is Online and is correctly reporting data (see [Cesium Documentation](#)).

Cesium: Jitter and Glitches while you move the real camera

Check the following in that order:

- 1) Is PRIME VSAR dropping ? See **above** for On Screen Verbosity. Check Output Log for any error messages regarding dropped or late frames.
- 2) Is PRIME VSAR video output properly set-up? Without moving the camera, run an animation, it should be flawless. Alternatively you can create an Actor with a Rotating Component (this will save you time wrt to creating an animation). Solutions could be: bad video cables, bad overall video path configuration, field inversion, ...
- 3) Is PRIME VSAR properly genlocked to the cesium camera data? PRIME VSAR video output and Cesium camera data device should be genlocked to the same genlock source. If it's not the case, and if you are in autoReconnect mode you should have regular “Camera:resync” messages in the Console output of Unreal.

Test DataEngine/PRIME VSAR connection

- 1) Open a web browser and type `http://<ip>:4300`. For IP use the IP of the PRIME VSAR system.
- 2) Open bucket ue4. If it does not exist, create it. ("ue4" is used for backwards compatibility)
- 3) Open key lua_in. If it does not exist, create it.
- 4) Type `PrintLog(42)`



- 5) Click Save (the request is send on Save)

If everything goes well, PRIME VSAR should print 42 in its Output Log (Window>Developer Tools>Output Log) something like:

MtRemoteControlLog: luaHelper.cpp (line 49, Hmc::UE4Lua::PrintLog): 42

```
MtCesiumLog: MtCesiumReceiver.cpp (line 127, FMtCsCameraQueue::Synchronize): FMtCsCameraQueue::Synchronize( 3179097 )
MtCesiumLog: MtCesiumReceiver.cpp (line 127, FMtCsCameraQueue::Synchronize): FMtCsCameraQueue::Synchronize( 3179150 )
LogMtDataEngine: Display: MtDataEngineReplier.cpp (line 176, UMtDataEngineReplier::EventReceived): bucket(ue4) != _channel(#reqrep
MtRemoteControlLog: luaHelper.cpp (line 49, Hmc::UE4Lua::PrintLog): 42
MtCesiumLog: MtCesiumReceiver.cpp (line 127, FMtCsCameraQueue::Synchronize): FMtCsCameraQueue::Synchronize( 3179211 )
MtCesiumLog: MtCesiumReceiver.cpp (line 127, FMtCsCameraQueue::Synchronize): FMtCsCameraQueue::Synchronize( 3179263 )
```

Test Video Input

PRIME VSAR relies on HAL to manage video in a general manner.

- 1) From the VSAR Content browser, add a Add/Import>Media>HAL Media Source.

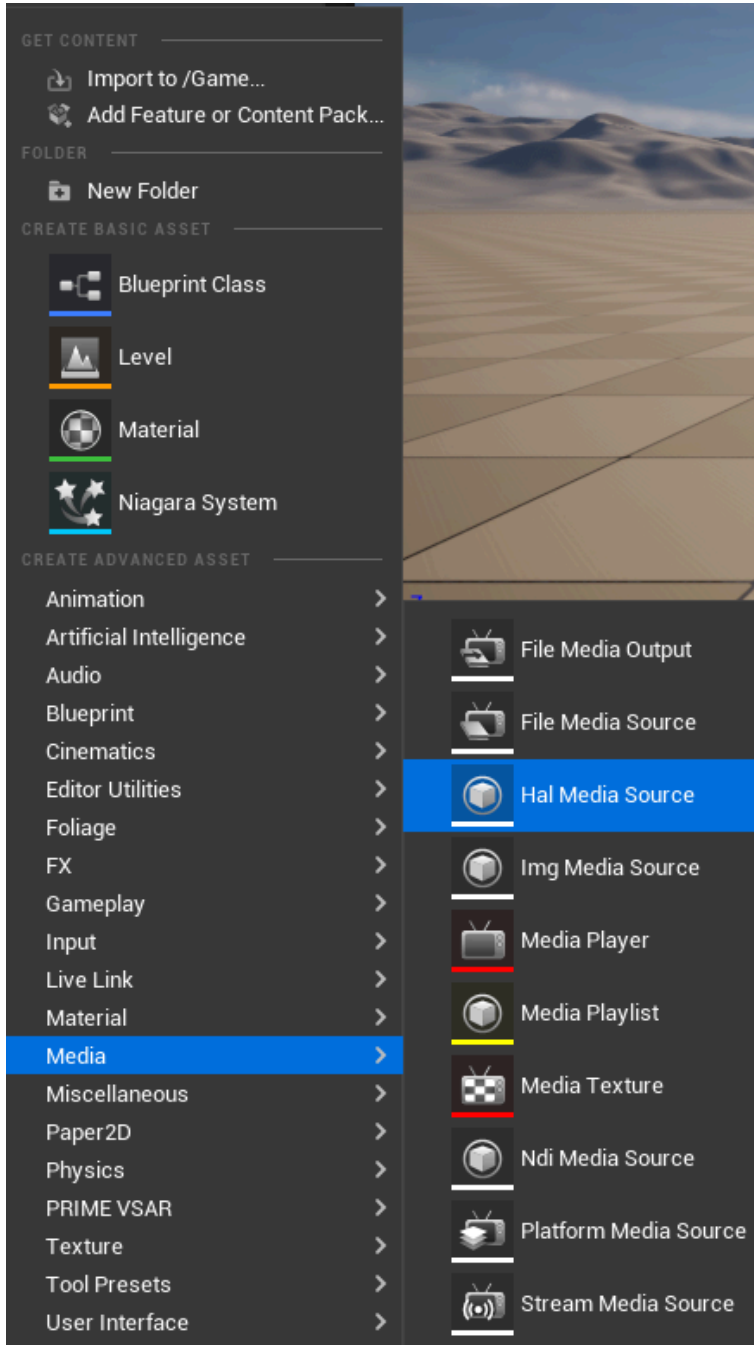

- 2) From Unreal Content browser, add a Add/Import>Media>Media Player.
You may consider checking the checkbox that labels Video output Media Texture asset, since that would be needed to be used on a material as a texture.

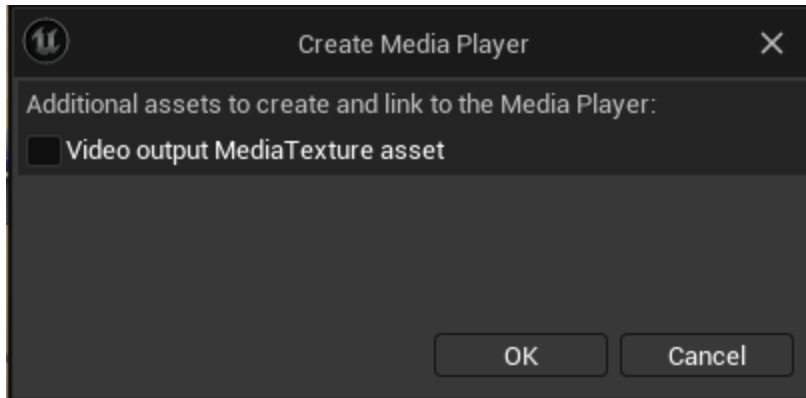

Use the predefined HAL Media Source in the Media player. The URL address bar should display something like hal://input0_0.

You should be able to monitor the video from there.

- 3) If expecting to use it on an object through a textured material you should have checked the Video output Media Texture asset at the previous step, or, alternatively, from the VSAR browser, add a new>Media>Media Texture and use the previous Media Player as Media.

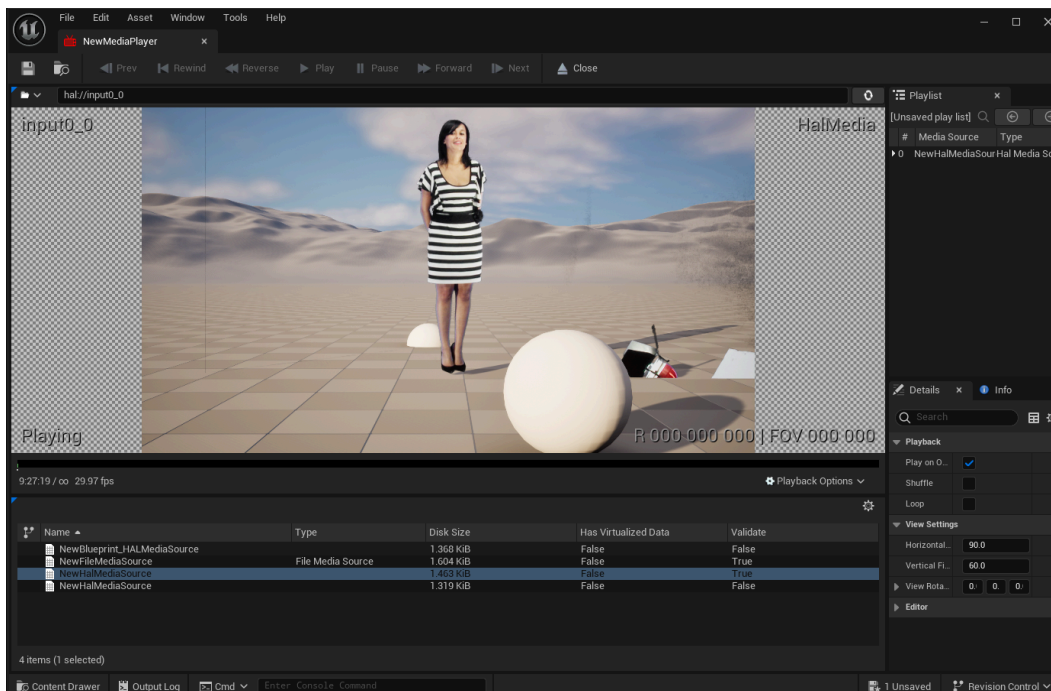

HAL Media Source

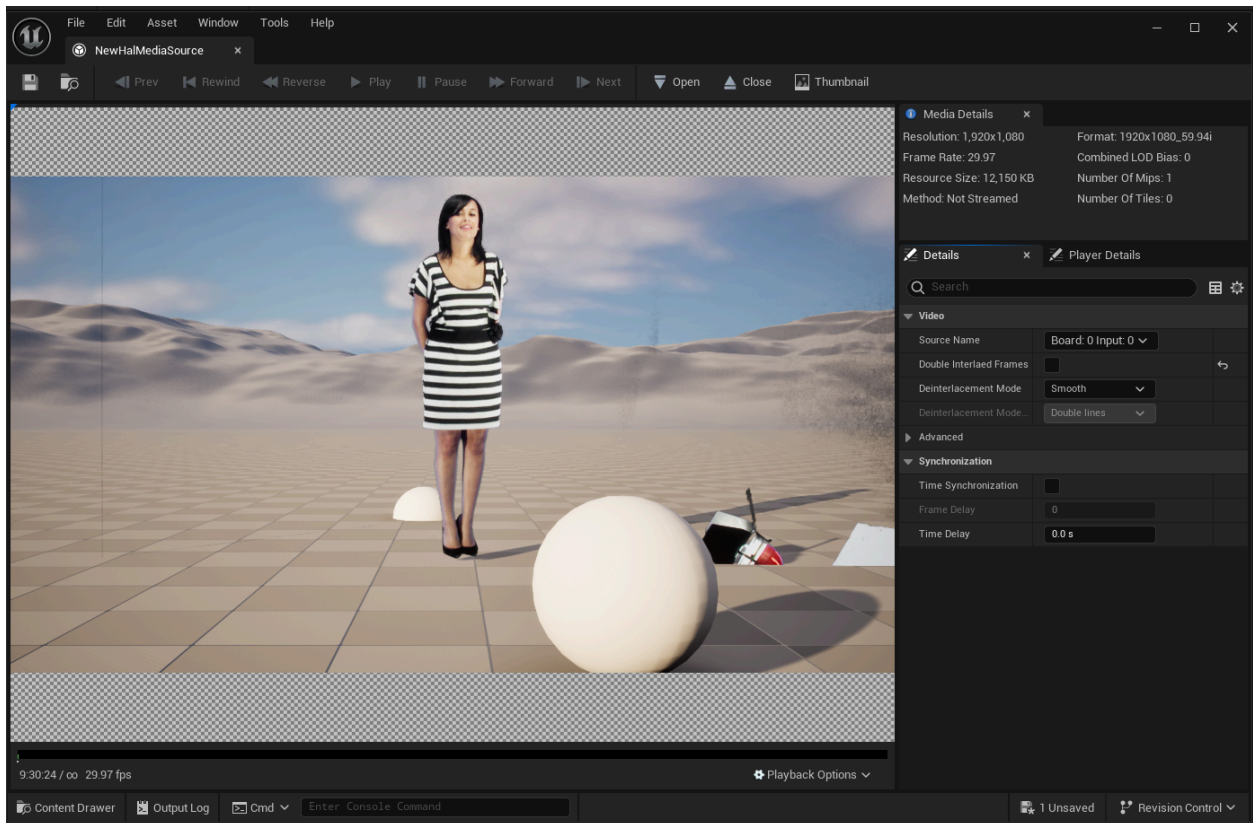

Source Name

The input ID as defined in the HAL.xml configuration file, more likely hal://input0_0.

Double interlaced Frames

When enabled, the interlaced format input aims to run at full fps. example: 50i running at 50 fps. and when disabled 50i is running at 25 fps

Deinterlacement Mode

Selects the preferred deinterlacing algorithm, applicable only when when Double interlaced Frames is disabled:

- Keep: keep both field as is - no deinterlacement
- Discard: keep even or odd field and discard second depending on the odd priory
- Blend: blends between fields using average

- Smooth: automatically detect if deinterlacing needs to be done. Usually this setting should be preferred.

Deinterlacement Mode Doubled

Selects the preferred deinterlacing algorithm, applicable only when when Double interlaced Frames is enabled:

- Keep: keep both field as is - no deinterlacement
- Half size: reduces vertical resolution by half example: 1920x1080 to 1920x540
- Double Lines: doubles the lines for each field, this can reduce perceived vertical resolution by half and can cause Bobbing. - sometimes called "Bob"
- Blend: blends between fields using average
- Lerp: doubles lines by blending between them using average. can be more performance intensive

Log Drop Frame: logs dropped frames that the Media player has dropped

Max Num Video Frame Buffer: maximum number of frames in buffer before Media player shows them, interlaced format is using two buffer frames each other frame when Double interlaced Frames is enabled

Odd Priory

when using Deinterlacement Mode like Discard this value decides which frames are not discarded. example: if disabled odd fields will be discarded and when enabled even fields will be discarded.

Synchronize with Engine's Timecode

Irrelevant here.

Time Delay

delay of the playback. the value is in seconds. if we use input with 50 fps - 0.02s here will mean a single frame of delay - this value can't be larger than Max Num Video Frame Buffer in frames or it will result in black screen as all frames will be dropped before the requested delay is reached. applicable only when Synchronize with Engine's Timecode is disabled

 Timestamp is currently not supported

Procedure to report issues

- 1) In case of a crash, open your project folder.
- 2) Go to Saved/Crashes/
- 3) Make a zip with the folder(s) inside and send it to support@chyronhego.com
- 4) Please provide steps to reproduce
- 5) Please provide specific VSAR Version, Cesium Version, VSAR Tools Version

In the case of Visual bug:

- 1) Capture screenshots
- 2) Send them to support@chyronhego.com
- 3) Please provide steps to reproduce
- 4) Please provide specific VSAR Version, Cesium Version, VSAR Tools Version

In the case of I/O Bug/Issue:

- 1) Copy Hal.xml from %LOCALAPPDATA%/Chyronhego/Fresh/HAL.xml
- 2) Send it to support@chyronhego.com
- 3) Please provide steps to reproduce
- 4) Please provide specific VSAR Version, Cesium Version, VSAR Tools Version

In all cases it is also helpful to send over a copy of the project to rule out any project specific issues, if possible.

PRIME VSAR: CAMIO INTEGRATION

Integration Overview

The integration of PRIME VSAR into the CAMIO universe relies on the native Data Engine's Request/Reply messaging system and implements the Bluenet Device API.

4 types of services are involved when CAMIO/iSQ commands are sent to PRIME VSAR:

- Data Engine
- Endpoint
- Endpoint Handler
- Request Dispatcher (optional in case of a single playout device)

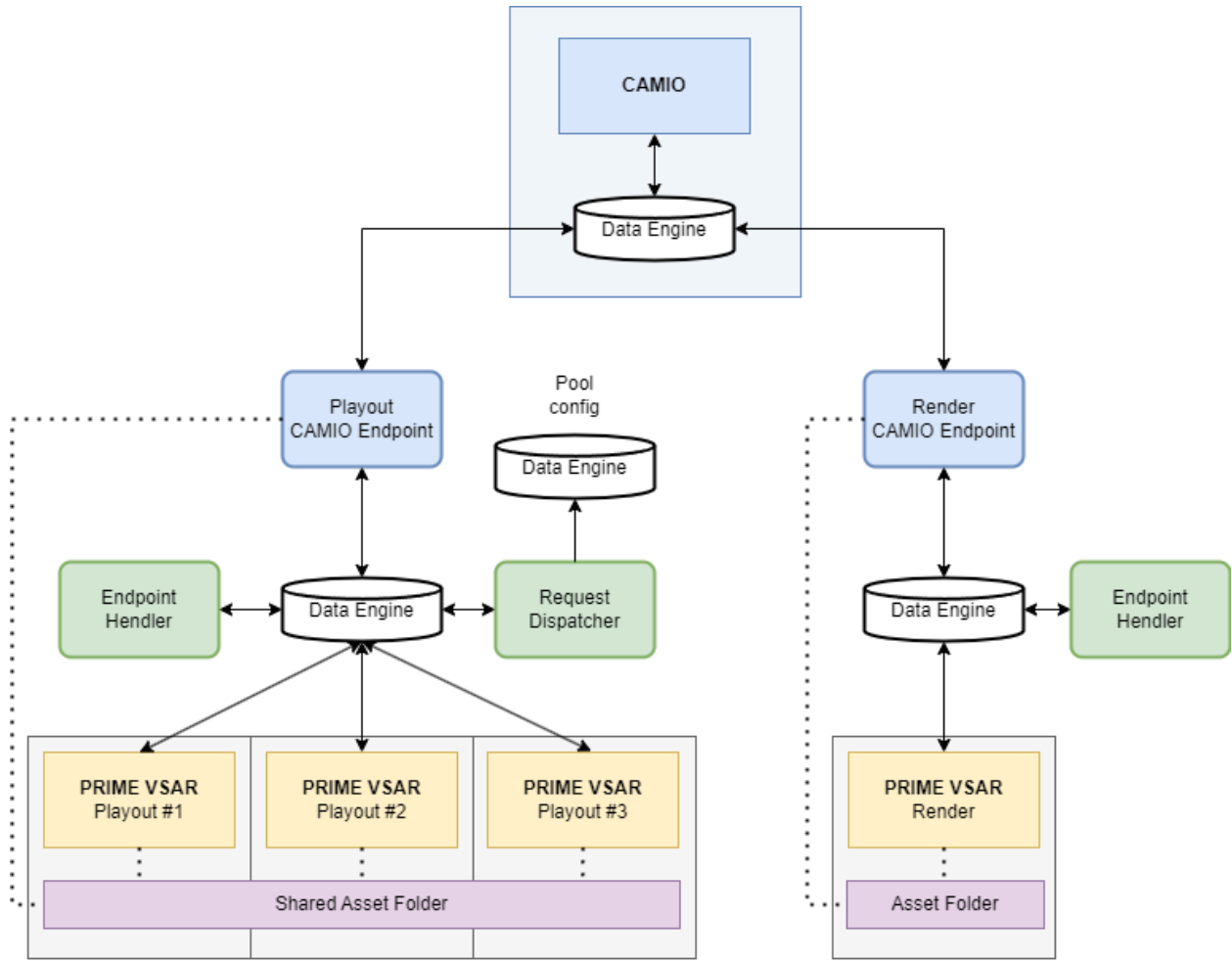

Example of installation with a pool of 3 playout devices and 1 Render

Camio Components

Data Engine

The Data Engine is the communication layer of all CAMIO commands with PRIME VSAR.

⚠ You should install at least one Data Engine for the playout device (or pool of playouts devices) and one for the preview device (cf. **Data Flow diagram**). The Data Engine on the CAMIO server should be already installed.

⚠ The Data Engine is bundled with Chyron Panels(LAP), so it should be already installed.

Once installed, a Windows service is started automatically and running in the background.

Download link: <https://da.chyronhego.com/da/download-area.php?proID=36>

Endpoint

The Endpoint is responsible for managing requests and template asset files from CAMIO. Therefore this service must have access to a shared folder in order to save the files, see the "Cache directory (Assets folder)" section for more details.

The Endpoint could be installed on a dedicated machine or on a playout/preview machine.

⚠ There should be a single Endpoint running for all the playouts and a single one for the preview (cf. Data Flow diagram).

Once installed, a Windows service is started automatically and running in the background.

Download link: <https://da.chyronhego.com/da/download-area.php?proID=55>

Endpoint Handler

This service handles requests from the Endpoint and manages the states of on-air/cued items. The requests are then forwarded to the final device or to the Request Dispatcher in case of multiple devices (i.e. a pool).

The Endpoint Handler executable is included in the PRIME VSAR Tools installer.

⚠ If PRIME VSAR Tools has been previously installed, the services may need to be stopped manually (Win+R -> services.msc) in before proceeding to the upgrade.

Once PRIME VSAR Tools is installed, you can choose to register the service when asked

⚠ The service reads by default its configuration on the local Data Engine, make sure the bucket and key exist before starting the service (see the **Configuration** section) or it will fail to start.

Request Dispatcher

This service dispatches a request to a pool of devices, for example in case of multiple playouts devices. In the case of a single device, this service is not required.

The Request Dispatcher executable is included in the PRIME VSAR Tools installer.

⚠ If PRIME VSAR Tools has been previously installed, the services may need to be stopped before proceeding to the upgrade.

Once PRIME VSAR Tools is installed, you can choose to register the service when asked.

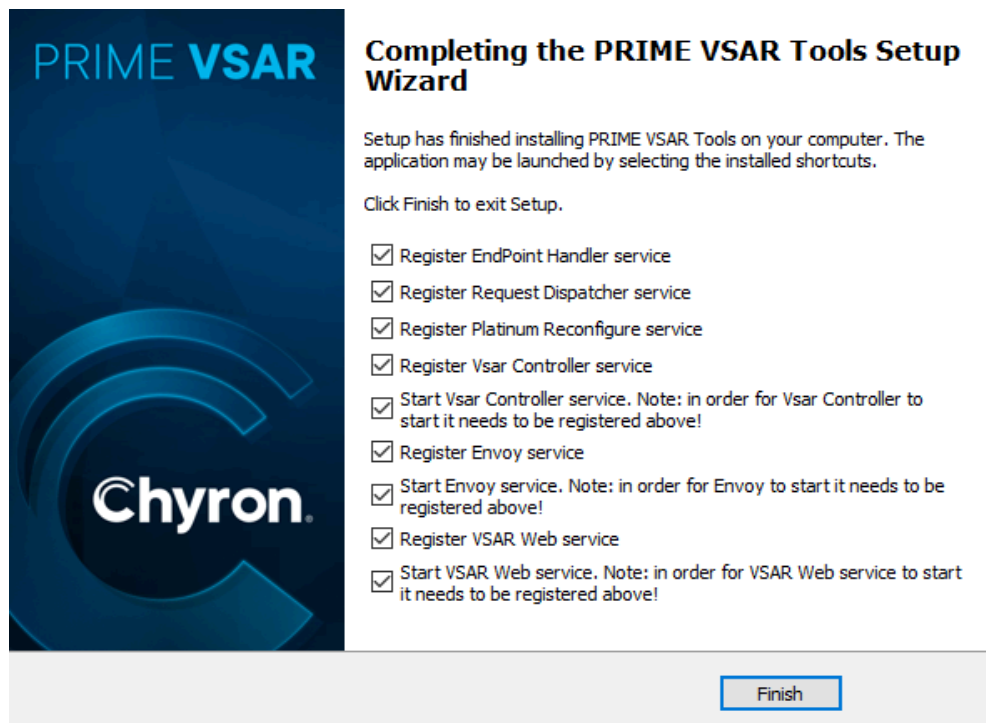

⚠ The service reads by default its configuration on the local Data Engine, make sure the bucket and key exist before starting the service (see the **Configuration** section) or it will fail to start.

Camio Configuration

Data Engine

⚠ Make sure the port 4300 is open on all machine were it is installed. You should be able to access `http://hostname:4300` (example `http://DESKTOP-MF15G8M:4300`) from the other machines.

For more information, please refer to the CAMIO Data Engine documentation.

Endpoint

Config key or config.json

The Endpoint could be configured either by a config.json file located by default in

`C:\Program Files\ChyronHego\ChyronHego CAMIO Endpoint Beta`, or by a config key in the bucket `bn.endpoint`

⚠ The config.json file takes precedence over the config key, so delete or rename config.json if you want to use the config key method.

⚠ The config.json file is recreated when reinstalling the service

Example

```
"isqHostName": "ip"  
"camioExternal": "camio4"
```

"isqHostName": If set, Endpoint will use this to find items in running order belonging to this host name instead of its own.

⚠ The hostname must match the hostname visible in the rundown's JSON.

"camioExternal": It must be set to "camio4" (lower case) for backward compatibility with CAMIO 4.11.2

⚠ If not set, the Endpoint will fail to upload previews on CAMIO.

For more information, please refer to the CAMIO Endpoint documentation

Or in its folder installation:

e.g. C:\Program Files\ChyronHego\ChyronHego CAMIO Endpoint Beta\doc\config.md

Cache directory (Assets folder)

In order to share the assets between multiple playout devices, the Endpoint cache directory must be shared.

These steps can be done manually or can be handled by the tool **platinum-reconfigure**.

1. Create a folder and set it up as a Windows shared folder
2. Create a symbolic link on each playout device pointing to the shared folder
This step provides a solution to map UNC paths to "Drive Letter" paths, e.g. with cmd:
mklink /d c:\sharedfolder \\COMPUTER\sharedfolder
3. Set the Endpoint config key or config.json accordingly e.g.:
"tempPath": "c:/sharedfolder"

Endpoint Handler

The Endpoint Handler could be configured either by arguments on the command line or by a config key in the bucket hybrid.endpointhandler

Command line arguments

-d, --dst <ARG1>

Destination device where requests should go (e.g. MyPoolId|localhost|192.168.1.42). Mandatory

-t, --type <ARG1>

Destination device's type (playout|render). Mandatory

-f, --shared_folder <ARG1>

Shared folder of the CAMIO device. Fallback if I disk can not be found

-h, --host <ARG1>

IPv4 address|host of this service's DataEngine. DEF: localhost

-s, --src_host <ARG1>

IPv4 address|host of the Endpoint's DataEngine. DEF: localhost

-c, --channel <ARG1>

Device's number of channels. DEF: 1

-o, --timeout <ARG1>

Requests timeout in ms. DEF: 5000

-l, --log <ARG1>

Log level. DEF: info (error|warn|info|verbose|debug|silly)

-v, --version

Print version number

--svc_args <ARG1>

IPv4 address|host of the DataEngine with the service args (svc mode)

Config key

In order to use the config key, the argument --svc_args must be specified.

 The config key takes precedence over the command line arguments when the argument --svc_args is specified and cannot be mixed.

The key is a JSON object with attributes similar to the command line arguments.

```
{  
  "dst": "localhost",  
  "type": "playout",  
}
```

 Logs are written to c:/log/ChyronHego/endpoint-handler

Request Dispatcher

Pool of playout devices

In AR/VR, a virtual set or AR graphics could be viewed from different camera angles.

Thus the concept of a pool of playout devices has been introduced to define multiple devices working together while still being seen as a single device from the CAMIO side.

Request Dispatcher needs to run only on “master” VSAR.

Make sure the bucket hybrid.pools exists otherwise create it.

Example

Key pool.Pool1 in the bucket hybrid.pools :

```
{
  "name": "Pool1",
  "master": "Pt2",
  "slaves": [
    "Pt1",
    "Pt3"
  ],
  "share": {
    "folder": "camio-endpoint",
    "type": "smb"
  }
}
```

Pt1, Pt2, Pt3 = are Hostnames but it can be also ip address

The Request Dispatcher could be configured either by arguments on the command line or by a config key in the bucket hybrid.requestdispatcher

Command line arguments

-p, --pool <ARG1>

Pool Id where requests will be dispatched (e.g. 'MyPoolId'). Mandatory

-c, --cfg_host <ARG1>

IPv4 address|host of the DataEngine with the Pool config. DEF: localhost

-s, --src_host <ARG1>

IPv4 address|host of the Endpoint Handler's DataEngine. DEF: localhost

-h, --host <ARG1>

IPv4 address|host of this service's DataEngine. DEF: localhost

-r, --resolve <ARG1>

Request resolution policy. DEF: all (all|any|race)

all: A request is resolved if all devices reply successfully

any: A request is resolved if at least one device reply successfully

race: The request resolution is determined by the first (fastest) device to reply successfully or not.

-x, --exclusive

Exclude the master from the pool DEF: not exclusive

-o, --timeout <ARG1>

Requests timeout in ms. DEF: 2000

-l, --log <ARG1>

Log level. DEF: info (error|warn|info|verbose|debug|silly)

-v, --version

Print version number

--svc_args <ARG1>

IPv4 address|host of the DataEngine with the service args (svc mode)

Config key

In order to use the config key, the argument --svc_args must be specified.

 The config key takes precedence over the command line arguments when the argument --svc_args is specified and cannot be mixed.

The key is a JSON object with attributes similar to the command line arguments.

```
{  
  "pool": "Pool1"  
}
```

 Logs are written to c:/log/ChyronHego/request-dispatcher

Platinum Reconfigure

platinum-reconfigure.js listens to the data engine to change the system configuration accordingly.

Prerequisites

- VSAR Tools (2.0.0+) installed on each playout. It includes the service platinum-reconfigure
- ISQ service installed on each playout. Only one service is needed at a time running on the master device but we prepare the other devices in advance in case of a pool reconfiguration. The Playout Endpoint Host is set to localhost (i.e. iSQ Service and Endpoint will be running on the master device)

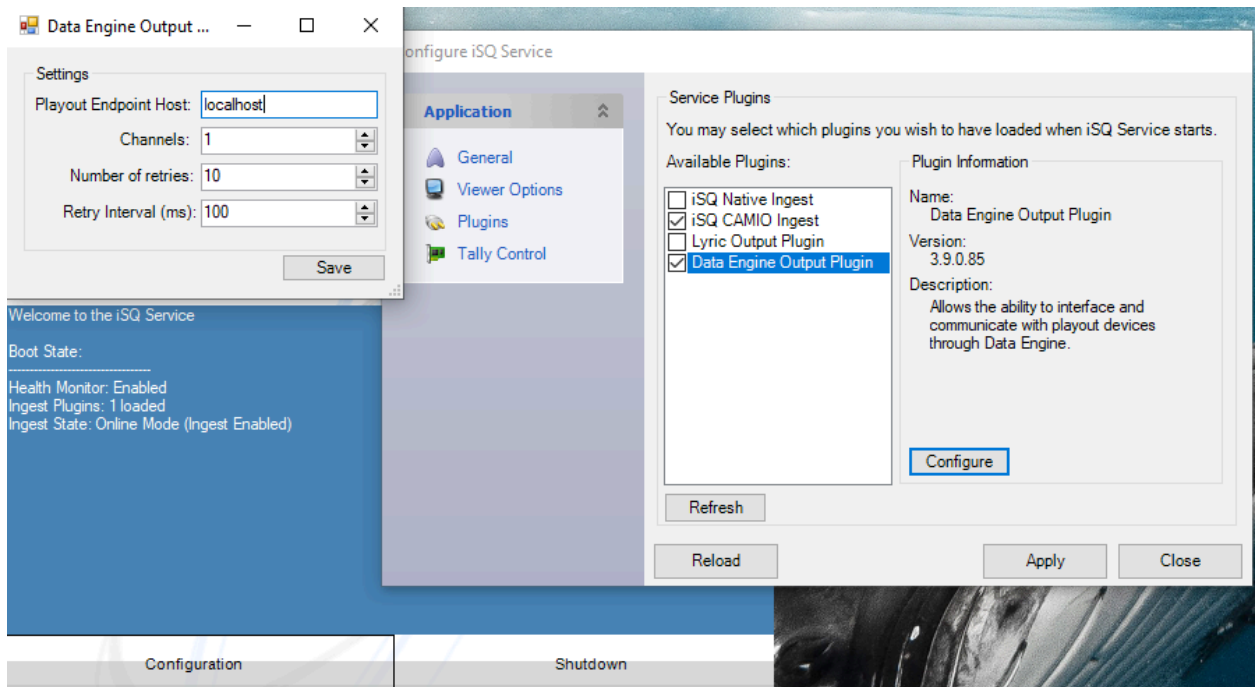

Reconfigure

USAGE: node `platinum-reconfigure.js` [OPTION1] [OPTION2]...

The following options are supported:

`--de <ARG1>` IP address of the dataengine on which the script will listen.

ex: node platinum-reconfigure.js `--de=localhost`

Pool

This tool can receive events to reconfigure the machine in a master/slave environment pool. A pool is a group of machines with 1 master and several slaves. In this use case, all machines of the pool are expected to run the service platinum-reconfigure, working with the same data engine.

This tool works with hostnames. So hostnames and IP correspondences are expected to be filled in the system.

On Windows:

C:\Windows\System32\drivers\etc\hosts

On the dataengine hybrid.pools bucket, each pool is described in a Key: pool.poolname This key needs to be created manually the first time regarding the needs.

Create in bucket hybrid.pools, the key pool.myPoolName (replace myPoolName by the pool's name, e.g. pool.Pool1) with the following content (example with FRESH3 as master and FRESH4 as slave):

Ex: pool.Pool1 Master on Windows (smb)

```
{
  "name": "Pool1",
  "master": "Pt2",
  "slaves": [
    "Pt1",
    "Pt3"
  ],
  "share": {
    "type": "smb",
    "name": "camio-endpoint",
    "drive": "S"
  }
}
```

In hybrid.pools bucket, each machine listen a Key that tell to which pool it belongs: device.hostname

Pt1, Pt2, Pt3 = are Hostnames but it can be also ip address

Ex: device.Pt2

```
{
  "pool": "pool.Pool1"
}
```

To re-arrange a pool, modify the pool description. Then overwrite the key of the new master. It will receive an event and configure itself as master. Then, when ready, it will write the keys of its slaves so they will reconfigure themselves as slaves.

For reconfiguration, external scripts are called:

- releaseMe.[sh-bat]
- masterMe.[sh-bat]
- slaveMe.[sh-bat]
- patchconfig.js

During the reconfiguration:

The script will read on the local data engine to get the share folder path in bn.endpoint bucket, config key, tempPath field. That's where the shared folder is. All machines are expected to have this field on the same value. Default is C:\Users\ChyronHego\AppData\Local\Temp

For the master VSAR device, it will modify hybrid.endpointhandler and hybrid.requestdispatcher buckets, config keys. endpointhandler and requestdispatcher services have to be installed and those keys have to exist.

For all VSAR devices, it will modify HOME\AppData\Local\Chyronhego\Fresh\Mithril.ini to update [/Script/Mithril.MtDataEngineHandler] section, Ip field to the master VSAR hostname.

PRIME VSAR - CAMIO Integration Troubleshooting

Notes

iSQ web interface (experimental) is located at <http://localhost:8087/isq>

Bluenet (Endpoint) log web interface (experimental) is located at <http://localhost:8087/log>

Data Engine web interface is located at <http://localhost:4300>

 Data Engine logs are written to `c:/log/ChyronHego/dataengine`

 Endpoint logs are written to `c:/log/ChyronHego/camio-endpoint`

 Endpoint handler logs are written to `c:/log/ChyronHego/endpoint-handler`

 Request dispatcher logs are written to `c:/log/ChyronHego/request-dispatcher`

Check list

- **All the machines can ping each other**
- **Endpoint config file is either** `config.json` **or a config key in the bucket** `bn.endpoint`
- Port 4300 is open on every machine hosting a Data Engine
- All services are running: Data Engine, Endpoint, Endpoint Handler, Request Dispatcher (optional, only needed for pool of playouts)
- All MOS/CAMIO server related services are running (e.g. External Render Service)
- All PRIME VSAR are connected to their respective Data Engine

Symptoms

A service is failing to read its config key on the Data Engine

(Failed to read args on the Data Engine, exiting...)

- Verify the Data Engine is running
- Verify the bucket and config key are existing and named accordingly without heading or trailing spaces
- Verify the config key's content is a valid JSON object

The rundown is selectable in iSQ web interface but is empty, iSQ Viewer displays the rundown but commands have no effect ("item not found" or "0/0 assets" in the Endpoint logs)

- Verify Endpoint config file is either config.json or a config key in the bucket bn.endpoint
- Verify the **Endpoint configuration** key "isqHostName": If set, Endpoint will use this to find items in running order belonging to this host name instead of its own.
- Restart the Endpoint service, and republish the rundown (e.g. in ENPS toggle 'MOS Control Active')

It should display in the log "Looking for items routed to XXX", XXX being the isqHostname

"X/X assets" with X not equal to 0

⚠ The hostname must match the hostname visible in the rundown's JSON.

The Request dispatcher is not able to see a slave machine ("Device 'xxx' is unreachable" in the logs)

- Check the Request dispatcher is pinging the slave machine
- Check the port 4300 is open on the slave machine (on the slave machine you should be able to access in a web browser the page located at <http://localhost:4300>)

You might need to disable/reconfigure the firewall on Windows

The context is not visible in LUCI 4 / 5

- Check the Context Permission in the CAMIO Admin tool (cf. CAMIO documentation)

The playout/preview fails

- Check there is no ID clash between the PRIME VSAR instances. For example 2 previews having the same ID and running at the same time will cause issues.
- Check PRIME VSAR is running in PLAY mode